

VIRGINIA STATE POLICE



MOTOR VEHICLE SAFETY INSPECTION MANUAL

Approved

March 17, 2026

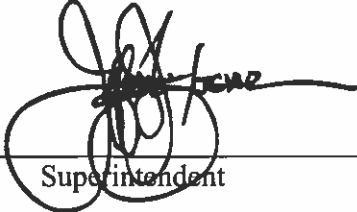

Superintendent



Virginia Motor Vehicle Safety Inspection Manual

Direct Inquiries or Comments to the Address Below:

Safety Division
Department of State Police
P.O. Box 27472
Richmond, Virginia 23261

For Additional Information Contact the Following Numbers:

Inspection Supplies:	804-278-5322
Station Files:	804-278-5303
	804-278-5306
Station Applications:	804-278-5308
Inspector/Mechanic Records:	804-278-5308
Station Fees Collection:	804-278-5320
	804-278-5321
Safety Division Headquarters:	804-278-5305
Safety Division Email:	safety@vsp.virginia.gov

Local Area Safety Offices:

Richmond	804-743-2217
Culpeper	540-829-7414
Amherst	434-946-7676
Wytheville	276-228-6220
Waverly	804-834-2368
Salem	540-387-5437
Fairfax	703-803-2622

To View the Virginia Motor Vehicle Safety Inspection Manual:
<https://vsp.virginia.gov/safety-and-enforcement/safety-division/>

**MOTOR VEHICLE SAFETY INSPECTION
RULES AND REGULATIONS
CHAPTER 70**

Table of Contents

Guidelines for the Administration of Virginia’s Annual Motor Vehicle Inspection Program

PART I	PAGE #	Administration
19VAC30-70-1	7	Purpose and Authority
19VAC30-70-2	8	Corrective Action Procedures
19VAC30-70-3	9	Class I Offenses
19VAC30-70-4	10	Class II Offenses
19VAC30-70-5	11 – 12	Class III Offenses
19VAC30-70-6	13 – 14	Class IV Offenses
19VAC30-70-7	15	General Information
19VAC30-70-8	16	Definitions
19VAC30-70-9	17 – 18	Inspector Requirements
19VAC30-70-9.1	19 – 21	Inspector Certification
19VAC30-70-9.2	22 – 25	Examination for Inspector’s License
19VAC30-70-9.3	26	Reinstatement of Safety Inspector License Classification Change; Recertification

Inspection Requirements 27

PART II	PAGE #	Inspection Requirements
19VAC30-70-10	28 – 31	Official Inspection Station Requirements
19VAC30-70-10.1	32 – 36	Official Inspection Station Appointment
19VAC30-70-11	37 – 38	Automated Motor Vehicle Inspection Program (MVIP)
19VAC30-70-20	39 – 40	General Inspection Requirements
19VAC30-70-25	41 – 43	Exceptions to Motor Vehicle Inspection Requirements
19VAC30-70-40	44 – 45	Fees
19VAC30-70-50	46 – 49	Approval Stickers and Decals
19VAC30-70-60	50 – 51	Rejection Stickers

Inspection Requirements for Passenger Vehicles and Vehicles Up to 10,000 Pounds (GVWR)

PART III	PAGE #	Up to 10,000 Pounds
19VAC30-70-80	53 – 58	Service Brakes
19VAC30-70-90	59	Brakes: Emergency, Parking, or Holding
19VAC30-70-100	60	Brakes: Trailer (GVWR less than 10,000 pounds)
19VAC30-70-110	61 – 68	Steering and Suspension
19VAC30-70-120	69	Frame, Engine Mounts, Coupling Devices and
19VAC30-70-130	70 – 72	Tires; Wheels; Rims
19VAC30-70-140	73 – 78	Headlamps; Except Motorcycles
19VAC30-70-150	79	Rear Lamps: Tail Lamp: and Rear Lamp Combinations
19VAC30-70-160	80 – 83	Auxiliary Lamps: Backup; Cornering; Driving; Fog; Spot and Warning
19VAC30-70-170	84	Parking Lamps
19VAC30-70-180	85 – 87	Clearance Lamps, Side Marker Lamps and Reflectors
19VAC30-70-190	88 – 89	Signal Device (Intention to Stop or Turn), Hazard Lights, Stop Lamp
19VAC30-70-200	90	Permissible Lighting Equipment
19VAC30-70-210	91 – 94	Glass and Glazing
19VAC30-70-220	95	Mirrors
19VAC30-70-230	96	Windshield Wiper; Defroster
19VAC30-70-240	97	Horns and Other Warning Devices
19VAC30-70-250	98	Doors
19VAC30-70-260	99	Hood Latch System; Batteries
19VAC30-70-270	100	Floor Pan
19VAC30-70-280	101	Seat
19VAC30-70-290	102 – 104	Seat Belts; Definitions
19VAC30-70-300	105	Muffler, Exhaust Systems and Trailer Venting
19VAC30-70-310	106	Air Pollution Control System or Device
19VAC30-70-320	107	Fuel System

Inspection Requirements for Motorcycles

PART IV	PAGE #	Motorcycles
19VAC30-70-340	109 – 110	Brakes
19VAC30-70-350	111 – 112	Airbag, Seat, Steering, and Suspension
19VAC30-70-360	113 – 115	Lights: Headlamp, Rear, Signal, Warning
19VAC30-70-370	116	Mirror
19VAC30-70-380	117	Horn
19VAC30-70-390	118	Muffler and Exhaust System
19VAC30-70-400	119	Tires; Wheels; Rims
19VAC30-70-410	120	Windscreen and Glazing
19VAC30-70-420	121	Fuel System

Inspection Requirements for Trucks and Other Vehicles Over 10,000 Pounds (GVWR)

PART V	PAGE #	Over 10,000 Pounds
19VAC30-70-430	123 – 130	Inspection Procedure for Heavy Vehicles
19VAC30-70-440	131 – 139	Service Brakes
19VAC30-70-450	140	Brakes: Emergency, Parking, or Holding
19VAC30-70-460	141	Brakes: Trailer (GVWR 10,000 Pounds or More)
19VAC30-70-470	142 – 147	Steering
19VAC30-70-480	148	Suspension
19VAC30-70-490	149 – 150	Frame, Engine Mounts, Coupling Devices and Emergency Chains
19VAC30-70-500	151 – 155	Tires; Wheels, Rims
19VAC30-70-510	156 – 162	Headlamps
19VAC30-70-520	163	Rear Lamps: Tail Lamp: and Rear Lamp Combinations
19VAC30-70-530	164	Auxiliary Lamps: Backup; Cornering; Driving Fog; Spot and Warning
19VAC30-70-540	165	Parking Lamps
19VAC30-70-550	166 – 170	Clearance Lamps, Side Marker Lamps, and Reflectors (Under 26,000 Pounds GVWR)
19VAC30-70-560	171 – 173	Signal Device (Intention to Stop or Turn), Hazard Lights, Stop Lamps
19VAC30-70-570	174	Permissible Lighting Equipment
19VAC30-70-580	175 – 178	Glass and Glazing
19VAC30-70-590	179	Mirrors
19VAC30-70-600	180	Windshield Wiper; Defroster
19VAC30-70-610	181	Horn and Other Warning Devices
19VAC30-70-620	182	Doors
19VAC30-70-630	183	Hood Latch System; Batteries
19VAC30-70-640	184	Floor Pan
19VAC30-70-650	185	Seat
19VAC30-70-660	186 – 187	Seat Belts
19VAC30-70-670	188	Muffler, Exhaust Systems and Trailer Venting
19VAC30-70-680	189	Fuel System

Inspection Requirements for Specialty Vehicles

PART VI	PAGE #	Specialty Vehicles
19VAC30-70-690	191	Inspection Requirements for Specialty Vehicles

Part I
Guidelines for the Administration of Virginia's
Annual Motor Vehicle Inspection Program

19VAC30-70-1. Purpose and authority.

Virginia's Official Motor Vehicle Inspection Program was developed and adopted to promote highway safety. The program model is based on the National Highway Traffic Safety Administration Federal Motor Vehicle Safety Standards. Vehicles submitted for inspection must be compliant with Federal Motor Vehicle Safety Standards applicable on the date of manufacture. The goal of the Official Motor Vehicle Inspection Program is to assure all Virginia registered vehicles are mechanically safe to operate over the highways of the Commonwealth.

The rules and regulations governing the Official Motor Vehicle Inspection Program are contained in the Official Motor Vehicle Safety Inspection Manual. These rules and regulations are promulgated under the authority of Chapter 10 (§ 46.2-1000 et seq.) of Title 46.2 of the Code of Virginia. All official inspection stations shall comply with these rules and regulations, issuing approval certificates only to those vehicles which the inspections shall determine to be in compliance with those rules and regulations.

For devices or equipment required to be approved pursuant to § 46.2-1005 of Title 46.2 of the Code of Virginia, the Superintendent may waive such approval and the issuance of a certificate of approval when the device or equipment is identified as complying with the standards and specifications of the Society of Automotive Engineers (SAE), the American National Standards Institute (ANSI), or the regulations of the federal Department of Transportation (DOT).

These rules and regulations are intended to ensure a uniform system of corrective action for those who violate the rules and regulations of the Official Motor Vehicle Inspection Program.

The Official Motor Vehicle Safety Inspection Manual covers administrative procedure as well as numerous vehicular safety items of varying importance. It is, therefore, necessary that the various sections of the manual be divided into categories of seriousness. This will provide a uniform system of corrective action for the certified inspectors and the inspection stations.

19VAC30-70-2. Corrective action procedures.

These procedures are intended to establish an equitable and effective process for recognizing and correcting unacceptable work performances. When multiple offenses arise out of the same act or inspection, disciplinary action will be taken on the most serious offense. All classes of offenses will apply uniformly to the inspectors involved in the offenses and management alike, where it is revealed that management was involved in the matter or had knowledge of its occurrence.

Unacceptable work performance shall be divided into four groups of offenses based on the seriousness as they pertain to vehicle safety.

Specified disciplinary action for each class offense shall not be exceeded. However, if additional aggravating circumstances exist, the appropriate corrective action will be taken.

19VAC30-70-3. Class I offenses.

Class I offenses are unacceptable work performances less serious in nature, but which require correction in order to maintain an efficient and effective Official Motor Vehicle Inspection Program. A violation of any paragraph of the following sections of the Official Motor Vehicle Safety Inspection Manual and rules and agreements not covered in the Official Motor Vehicle Safety Inspection Manual or those disseminated by other means shall constitute a Class I offense, unless designated otherwise:

[19VAC30-70-10](#) A through D

[19VAC30-70-10](#) F through I

[19VAC30-70-10](#) K through O

[19VAC30-70-10](#) U

[19VAC30-70-20](#) in its entirety

[19VAC30-70-40](#) in its entirety

[19VAC30-70-50](#) in its entirety

[19VAC30-70-60](#) in its entirety

[19VAC30-70-80](#) B 3

[19VAC30-70-160](#) in its entirety (except subdivisions I 12 and 13 f (2))

[19VAC30-70-170](#) in its entirety

[19VAC30-70-200](#) in its entirety

[19VAC30-70-290](#) in its entirety

[19VAC30-70-310](#) in its entirety

[19VAC30-70-360](#) D 4 e and f

[19VAC30-70-410](#) in its entirety

[19VAC30-70-440](#) B

[19VAC30-70-530](#) in its entirety (except subdivisions K 10 i and K 11 g (2))

[19VAC30-70-540](#) in its entirety

[19VAC30-70-570](#) in its entirety

[19VAC30-70-660](#) in its entirety

Disciplinary action for Class I offenses shall be:

1st offense – Verbal counseling - Recorded on Form SP-164.

2nd offense – Written reprimand from the safety officer or his/her designee.

3rd offense – Suspension of not less than 15 or more than 30 days.

Offenses shall be cumulative in nature and shall remain active for 24 months from date of offense. When Class II, III, or IV offenses are active, discipline can be written reprimand or suspension of not more than 60 days.

19VAC30-70-4. Class II offenses.

Class II offenses shall be violations of any section of the Official Motor Vehicle Safety Inspection Manual considered very serious but the consequence of such violation or omission is not likely to be an imminent cause or contributing factor to a traffic crash or other vehicle related injury. A violation of the following sections of the Official Motor Vehicle Safety Inspection Manual shall constitute a Class II offense unless designated otherwise:

[19VAC30-70-150](#) in its entirety
[19VAC30-70-180](#) in its entirety
[19VAC30-70-210](#) in its entirety
[19VAC30-70-230](#) in its entirety
[19VAC30-70-240](#) in its entirety
[19VAC30-70-250](#) in its entirety
[19VAC30-70-260](#) in its entirety
[19VAC30-70-270](#) in its entirety
[19VAC30-70-280](#) in its entirety
[19VAC30-70-300](#) in its entirety
[19VAC30-70-320](#) in its entirety
[19VAC30-70-360](#) A 7 and C
[19VAC30-70-380](#) in its entirety
[19VAC30-70-390](#) in its entirety
[19VAC30-70-420](#) in its entirety
[19VAC30-70-520](#) in its entirety
[19VAC30-70-550](#) in its entirety
[19VAC30-70-580](#) in its entirety
[19VAC30-70-600](#) in its entirety
[19VAC30-70-610](#) in its entirety
[19VAC30-70-620](#) in its entirety
[19VAC30-70-630](#) in its entirety
[19VAC30-70-640](#) in its entirety
[19VAC30-70-650](#) in its entirety
[19VAC30-70-670](#) in its entirety
[19VAC30-70-680](#) in its entirety

Disciplinary action for a Class II offense shall be:

- 1st Offense – Verbal counseling - Recorded on Form SP-164.
- 2nd Offense – Written reprimand from the safety officer or his/her designee.
- 3rd Offense – Suspension of not less than 30 or more than 60 days.

Offenses are cumulative in nature and shall remain active for a period of 24 months from date of offense. When Class I, III, or IV offenses are active, discipline can be written reprimand or suspension of not more than 90 days.

19VAC30-70-5. Class III offenses.

Class III offenses may be violations of those sections of the Official Motor Vehicle Safety Inspection Manual considered more severe in nature, and usually considered most critical from a safety or administrative viewpoint. They would include the omission of checking or improper approval of an item so critical to the safe operation of a motor vehicle as to have the potential of being the imminent cause or factor of a motor vehicle crash. A violation of the following sections of the Official Motor Vehicle Safety Inspection Manual shall constitute a Class III offense unless designated otherwise:

- [19VAC30-70-10](#) J, P, and Q
- [19VAC30-70-11](#) in its entirety
- [19VAC30-70-80](#) in its entirety (except subdivision B 3)
- [19VAC30-70-90](#) in its entirety
- [19VAC30-70-100](#) in its entirety
- [19VAC30-70-110](#) in its entirety
- [19VAC30-70-120](#) in its entirety
- [19VAC30-70-130](#) in its entirety
- [19VAC30-70-140](#) in its entirety
- [19VAC30-70-160](#) I 12 g and 13 e
- [19VAC30-70-160](#) I 12 f and 13 f (2)
- [19VAC30-70-190](#) in its entirety
- [19VAC30-70-220](#) in its entirety
- [19VAC30-70-340](#) in its entirety
- [19VAC30-70-350](#) in its entirety
- [19VAC30-70-360](#) A and B
- [19VAC30-70-370](#) in its entirety
- [19VAC30-70-400](#) in its entirety
- [19VAC30-70-440](#) in its entirety
- [19VAC30-70-450](#) in its entirety
- [19VAC30-70-460](#) in its entirety
- [19VAC30-70-470](#) in its entirety
- [19VAC30-70-480](#) in its entirety
- [19VAC30-70-490](#) in its entirety
- [19VAC30-70-500](#) in its entirety
- [19VAC30-70-510](#) in its entirety
- [19VAC30-70-530](#) K 10 i and K 11 g (2)
- [19VAC30-70-560](#) in its entirety
- [19VAC30-70-590](#) in its entirety
- [19VAC30-70-690](#) in its entirety

Disciplinary action for a Class III offense shall be:

- 1st offense – Written reprimand from the safety officer or his/her designee.
- 2nd offense – Suspension for not less than 45 or more than 90 days.

3rd offense – Suspension for not less than 90 days or more than 6 months.

Offenses are cumulative in nature and will remain active for a period of 24 months from date of offense.

When Class I, II, or IV offenses are active, discipline can be written reprimand or suspension of any duration less than one year.

19VAC30-70-6. Class IV offenses.

- A. Class IV offenses are those violations considered so critically important to the integrity and credibility of the Official Annual Motor Vehicle Inspection Program as to require immediate and severe disciplinary action. Any Class IV offense is grounds for suspension or revocation. The following violations and actions shall be considered a Class IV offense:
1. Loss of driver's license, with the exception of an administrative court-ordered
 2. Obvious usage of either alcohol or drugs by an employee associated with the Annual Motor Vehicle Inspection Program.
 3. Loss of inspection stickers through neglect, or subsequent violations of subsection K of 19VAC30-70-10.
 4. Improper use of inspection supplies, such as placement on a vehicle that has not been inspected or failure to affix the inspection sticker to the vehicle in its proper location, after inspection.
 5. Falsifying inspection receipts or inspection records.
 6. Giving false information during an inspection complaint investigation.
 7. Performing an inspection at a station without authority from the safety officer.
 8. The arrest of any person associated with the inspection program for a criminal offense or the institution of civil action of a nature that would tend to immediately reflect upon the integrity and reputation of the Department of State Police may be grounds for an inactive inspector or station status until final court disposition. A finding other than acquittal for any criminal offense, civil judgment, or bankruptcy may result in a suspension or revocation of the inspector or station appointment, or both.
 9. The use of profanity or verbal abuse by station owners, managers, or safety inspectors toward each other or directed at customers presenting their vehicles for inspection.
 10. Illegal use of inspection supplies such as stealing, selling, mailing or giving away, or the attempt thereof.
 11. Nonpayment of inspection fees.
 12. Conduct displayed by station owners, managers, or safety inspectors that may be rude or discourteous, or the use of profanity or verbal abuse directed at or toward Safety Division Personnel.
 13. Failure of any person connected with the inspection program to notify their supervising trooper or Safety Division Area Office within 72 hours of an arrest for a criminal offense or the institution of civil action.
 14. Any misuse or falsification of the automated Motor Vehicle Inspection Program (MVIP) system through neglect, or intentionally allowing an assigned password or personal identification number (PIN) to be used by other persons.
 15. Willfully obtaining computer services without proper authority from the safety officer.
 16. Failure to adequately explain and differentiate, both orally and in writing, to customers what repairs are necessary to pass the safety inspection and those repairs that are only recommended. Each station shall explicitly (not fine print) convey to each customer when his/her vehicle will be examined beyond the parameters of the state inspection and empower the customer with the ability to decline this service.

17. Allowing a suspended or revoked safety inspector to perform predelivery inspections (PDIs) or have access to inspection supplies, which may be grounds for suspension or revocation of the station appointment and an additional suspension or revocation for the inspector.
- B. Disciplinary action for a Class IV offense shall be immediate suspension or revocation. A revocation shall not be less than one year or more than three years. A suspension shall constitute any period of time less than a year and shall not be less than 90 days, unless mitigating circumstances exist. Offenses are cumulative in nature and will remain active for a period of 24 months from the date of the offense. For a subsequent violation within 24 months, the suspension or revocation shall be no less duration than the prior discipline received.
- C. In the case of the loss of the driver's license, the suspension shall remain in effect until the driver's license is reinstated and consideration for reinstatement of inspection privileges will be made at that time.
- D. In cases concerning nonpayment of fees when the inspection station has been given 15 days to reply to a final notice, the suspension of the affected inspection station shall remain in effect until all inspection fees are paid. Consideration for reinstatement of inspection privileges will be made when all fees are paid. Furthermore, stations that have not paid their processing fee after the 15-day period will not be issued any additional inspection supplies. Supply orders may resume when the inspection fee is paid and the station has been reinstated to an active status.

19VAC30-70-7. General information.

All suspension or revocation decisions may be appealed. The request must be made in writing to the safety officer within 15 calendar days of receiving the official notice of suspension or revocation.

The suspension or revocation period for a subsequent violation requiring suspension or revocation under any class of offenses within a 24-month period shall be twice that of a previous suspension or revocation, unless mitigating circumstances exist. Any violation under any class of offenses requiring a third suspension within a 14-month period shall be grounds for revocation.

For suspension periods of less than six months, inspection stations and safety inspectors will not be required to file an application for reinstatement.

For suspension periods of six months or more, or revocation periods of one to three years, inspection stations must complete the process as set forth for original appointment. Reapplications may be made 60 days prior to the expiration of suspension periods only, not revocations. An inspection station that has its privilege to perform inspections revoked must complete the application process as set forth for original appointments after the expiration of the period of revocation.

Safety inspectors who are suspended for suspension periods of six months or more shall contact the appropriate Safety Division Area Office or supervising trooper to request reinstatement. Safety inspectors who have their privilege to perform inspections revoked must complete the application process for initial certification after the expiration of the period of revocation.

If during the course of an official investigation, station management voluntarily surrenders the station's inspection supplies, particularly after being cautioned not to do so, the station shall not be eligible for reinstatement for a period of 90 days. This voluntary action shall not be the subject of an appeal.

If during the course of an official investigation, an inspector voluntarily surrenders their inspector's license, particularly after being cautioned not to do so, the inspector shall not be eligible for reinstatement for a period of 90 days. This voluntary action shall not be the subject of an appeal.

19VAC30-70-8. Definitions.

The following words and terms when used in this chapter shall have the following meanings unless the context clearly indicates otherwise.

“MVIP” means the Motor Vehicle Inspection Program.

“Official Motor Vehicle Safety Inspection Manual” means this chapter ([19VAC30-70](#)).

“Official Safety Inspection Station or Official Inspection Station” means a bonafide garage or other facility that performs motor vehicle, motorcycle, or trailer repairs as a routine business, has met all criteria for appointment to perform safety inspections pursuant to Virginia's Annual Motor Vehicle Inspection Program, and has been issued a Certificate of Appointment by the Department of State Police.

“Revocation” means that the privilege or appointment is not subject to renewal or restoration except through reapplication after the expiration of the period of revocation. A period of revocation is from one to three years depending on the severity of the case.

“Safety inspector” or “inspector” means an individual who has successfully completed all the requirements for appointment and is certified by the Department of State Police to perform motor vehicle safety inspections pursuant to Virginia's Annual Motor Vehicle Inspection Program.

“Suspension” means that the privilege or appointment has been temporarily withdrawn, but may be reinstated following the period of suspension unless it has expired prior to the end of the period of suspension.

“Test site” means any location designated for Class A, B, and C certifications and all recertifications designated by the Department of State Police. A list of test sites is maintained in the MVIP system and at each Safety Division Area Office.

19VAC30-70-9. Inspector requirements.

- A. The inspection of motor vehicles required by this chapter shall be made only by those individuals who are certified and licensed as safety inspectors by the Department of State Police. The procedures outlined in this section are applicable to the processing of applications for initial certification, reclassification of safety inspector's licenses, and reinstatement of suspended or revoked safety inspector's licenses.
- B. All certified inspectors shall be at least 18 years of age and meet the following qualifications:
 - 1. A minimum of one year of practical experience as an automotive mechanic (six months of practical experience as an automotive mechanic combined with an additional and separate six months of mirroring a certified state inspector shall suffice as practical experience), or
 - 2. Satisfactorily completed a training program in the field of automotive mechanics approved by the Superintendent of State Police.

A person who has met either of the practical experience requirements in repairing motorcycles may be certified to inspect motorcycles only. A person who meets practical experience requirements in repairing trailers may be certified to inspect trailers only.

- C. Each mechanic entering the inspection program is required to satisfactorily pass a written and practical examination exhibiting knowledge of the inspection procedures.
- D. Each certified inspector shall possess a valid Virginia driver's license with the following exceptions:
 - 1. An inspector who is a resident of an adjoining state holding a valid driver's license in that state and who commutes regularly to work in Virginia; or
 - 2. A member of the armed forces of the United States on active duty, or a dependent or spouse thereof, who holds a driver's license from the inspector's home state.
- E. An inspector whose driver's license is suspended or revoked, including the seven-day administrative suspension for an arrest for driving under the influence (DUI), must immediately notify the station's supervising trooper or the local Safety Division Area Office of the suspension or revocation. The suspension or revocation of an inspector's driver's license shall automatically act as a suspension of the inspector's privilege to inspect motor vehicles until such suspension or revocation is terminated, and the reinstatement has been made by the Superintendent of State Police.
- F. Each licensed safety inspector must have a valid safety inspector's license in the inspector's possession at all times while conducting inspections.
- G. Each safety inspector with a valid safety inspector's license need only present such valid license to the inspector's new employer to commence participation in the program at a new place of employment. Management of the inspection station is required to notify the Safety Division when a safety inspector begins or ends employment. This notification may be handled by contacting the inspection station's supervising trooper by telephone.
- H. In the event the safety inspector's license becomes mutilated, lost, or stolen, the inspector must notify the Department of State Police immediately to request a duplicate using the Safety

Inspector Notification Form. All required information shall be printed legibly and completely. For an inspector who is not employed, writes "Inactive" in the station name block.

In those cases where notification is being made due to an address change, it is necessary to complete the Safety Inspector Notification Form and submit it to the Safety Division Headquarters. The inspector's information will be updated within the MVIP database by the Inspector Files Clerk.

NOTE: The Safety Inspector Notification Form can be downloaded from the Virginia State Police website under the Vehicle Safety Inspection link.

NOTE: Safety inspector licenses are only generated and distributed for initial certifications, renewals, name changes, and mutilated, lost, or stolen licenses. Inspectors submitting a change of address notification are not issued a new license.

- I. An inspector must notify the station's supervising trooper or Safety Division Area Office within 72 hours of an arrest for a criminal offense or the institution of a civil action.
- J. Requirements for safety inspector applicants with a specific learning disability.
 1. Applicants must furnish documentation from the particular school division where the applicant was classified as having a learning disability. The specific learning disability must be clearly identified.
 2. Once the learning disability has been documented, and if applicable, the applicant will be allowed to test with the written exam being orally presented.
 3. The station management, where the applicant is employed or to be employed, must agree to have someone present during the hours the employee is conducting inspections to assist with the reading of the Official Motor Vehicle Safety Inspection Manual when necessary during the initial three-year certification period. If the inspector changes stations within the first three-year period, it is the inspector's responsibility to notify station management of the inspector's disability and this requirement.

19VAC30-70-9.1. Inspector certification.

- A. Upon request, the Safety Inspector Application (Form SP-170B) and Criminal History Record Request (Form SP-167) are provided online via the Virginia State Police website to individuals desiring appointment as certified safety inspectors.
 - 1. The application pack includes instructions to help guide the applicant through the process.
 - 2. Applicants may be certified in any of the following classes after completing the necessary requirements and the appropriate examinations:
 - a. Class A: May inspect any motor vehicle, motorcycle, or trailer.
 - b. Class B: May inspect trailers only.
 - c. Class C: May inspect motorcycles only.
- B. Applicants should immediately prepare for the written examination by studying the Official Motor Vehicle Safety Inspection Manual in its entirety.
 - 1. The applicant must present the applicant's completed application in accordance with the provisions established in 19VAC30-70-9.2.
 - 2. If the applicant's driver's license is expired, suspended, or revoked, the applicant will be advised, and the application destroyed. The applicant may reapply after the applicant's driver's license is reinstated.
- C. The Class A inspector examination consists of five sections containing 20 questions each. A minimum score of 75% must be attained for each section. The Classes B and C inspector examinations will consist of 50 questions each. A minimum score of 74% must be attained. If the applicant fails the test, failure is noted at the end of Section I on the Form SP-170B with the word "failed" and the date. The application is returned to the applicant. Applicants failing to attain the minimum score are not allowed to test again for 30 days. Applicants failing a second or subsequent examination are not allowed to test again for six months.
- D. The Safety Inspector Application (Form SP-170B) and Criminal History Record Request (Form SP-167) for applicants who achieve a minimum score or greater is forwarded to Safety Division Headquarters.
 - 1. The applicant's record is checked against safety inspector and Central Criminal Records Exchange (CCRE) files.
 - 2. Inspection and criminal record information along with the applicant's driver transcript is forwarded with the application to the appropriate Safety Division Area Office for investigation.
 - 3. A credit check is performed to determine that the applicant associated with the inspection program is in compliance with any judgment order or is meeting all financial obligations, or both.
- E. A background investigation is conducted consisting of the following:
 - 1. Verification that the applicant is at least 18 years of age.
 - 2. Verification that the applicant has not less than one year's practical experience employed as an automotive technician repairing vehicles for the public, (six months of practical

experience as an automotive mechanic combined with an additional and separate six months of mirroring a certified state inspector shall suffice as practical experience) or has satisfactorily completed a training program in the field of automotive mechanics approved by the Department of State Police. The following training programs in the field of automotive mechanics have been approved as a substitute for the one year's practical experience requirement:

- a. The two-year associate degree or diploma programs in automotive technology offered by the Virginia Community College System consisting of the following minimum curriculum:
 - 1) Automotive Electrical Systems - three semester hours.
 - 2) Braking Systems - three semester hours.
 - 3) Emissions Control Systems - three semester hours.
 - 4) Suspension and Steering Systems - three semester hours.
 - 5) Vehicle Safety Inspection - two semester hours.
 - b. The 1,080-hour Career Technical Automotive Services Technology Program, offered by the Office of Career Technical Education, State Department of Education, in the various technical schools located throughout Virginia or be certified by the National Institute for Automotive Service Excellence (ASE), or both.
 - 1) Upon the successful completion of this course, including a practical test as defined in this section, the student must complete a Safety Inspector Application (Form SP-170B) and a Criminal History Record Request (Form SP-167), pass a written test as defined in subsection C of this section, and submit to a background investigation as defined in this subsection. Upon successful completion of these requirements, the student, if 18 years of age, is certified as a safety inspector and issued a safety inspector license.
 - 2) If the student scores less than 75% on any part of the examination, the application will be returned to the certifying trooper. Students scoring less than 75% on any part of the examination may retest at the certifying trooper's next recertification testing date, but not sooner than 30 days from the date of the last examination. If the student passes the test at this time and is at least 18 years of age, they are issued a safety inspector license. Upon the student's 18th birthday, providing they still meet all of the requirements, the student will be issued a safety inspector license.
 - 3) Students failing the second written examination are not allowed to test again for six months. In order to retest the student must be at least 18 years of age and must complete the application process set forth for original certification.
 - c. The 1,500-hour Course #1 entitled "Auto-Diesel Technician Course" offered by the Nashville Auto Diesel College, Inc., 1524 Gallatin Road, Nashville, Tennessee 37206.
3. A determination of the applicant's mechanical ability through interviews with employers and customers.
 4. A review of the applicant's current driving record on file with the Department of Motor Vehicles (DMV) is utilized in determining applicant's suitability for certification.

5. Determination of the character and reputation of the applicant through previous associates, employers, and records.
 6. Determination of the applicant's attitude toward the inspection program and receptiveness to State Police supervision through personal interview.
 7. The investigating trooper shall administer a practical examination to determine the applicant's ability to conduct a safety inspection. The applicant will conduct a complete inspection, including the use of the optical headlight aimer. This shall be conducted at the applicant's station of employment. If the applicant is not employed at a certified inspection station, the applicant may make arrangements with one to conduct practical testing.
- F. Any applicant whose application is voluntarily withdrawn may not reapply sooner than six months from the date of the withdrawal. Any applicant whose application is denied may not reapply sooner than 12 months from the date of the letter notifying the denial.
- G. When a safety inspector is certified, the bottom of the Form SP-170B is completed by the certifying trooper or MVIP investigator. The classification for which the safety inspector is being certified and the date of certification must be entered by the trooper on the bottom of the Form SP170B. The Form SP-170B shall then be forwarded to the Safety Division Area Office.
- H. Upon certification, the supervising trooper shall issue the inspector's license.
- I. All safety inspector licenses shall be valid for a period of three years.

19VAC30-70-9.2. Examinations for inspector's license.

- A. The Department of State Police administers the written examination for original certification for all inspectors. With few exceptions, recertifications are done at the normal testing sites along with original certification tests.
- B. In order for an individual to become a certified safety inspector, the following actions shall be followed:
 - 1. The person shall download the following forms from the Virginia State Police website:
 - a. Safety Inspector Application, Form SP-170B;
 - b. Criminal History Record Request, Form SP-167;
 - c. Inspector Application Worksheet;
 - d. Authorization for Release of Information (SP-170D).
 - 2. The applicant shall (i) complete Form SP-170B in its entirety and have it notarized; (ii) complete and have notarized Form SP-167 with appropriate credit card information or an attached \$15 cashier's check, business check or money order payable to "Virginia State Police"; and (iii) complete the Inspector Applicant Worksheet with two character references, two mechanical references, places of employment, and qualified automotive training, or schools completed or mechanical experience.
 - 3. The applicant shall then take the completed application forms to any State Police testing site and present it to the trooper conducting the written examination. Applicants arriving after the designated testing time are not eligible to participate in the written examination.
 - 4. The trooper verifies the notarizations and checks the driver's license for validity and identification of the applicant. If the applicant's driver's license is found to be expired, suspended, or revoked, the applicant is advised, and the application is destroyed. The applicant may reapply once the driver's license has been reissued or reinstated.
 - 5. If the applicant successfully passes the test, the trooper notes at the end of Section I on the Form SP-170B the word "passed" and the date. The trooper signs the test and sends it to Safety Division Headquarters, Inspectors File Section for further processing and investigation.
 - 6. The Class A examination consists of five sections: general information, brakes, suspension, lights, and glass. Each section contains 20 questions. A minimum score of 75% must be attained for each section and for the practical examination. The Classes B and C examinations consist of 50 questions each. A minimum score of 74 must be attained on the written and practical examination.
 - 7. If the applicant fails the test, failure is noted at the end of Section I on the Form SP170B with the word "failed" and the date.
 - 8. If the applicant desires to test again for the written or practical test, they may do so after 30 days. If the applicant is again unsuccessful in passing either examination, the trooper shall take the application forms and forward them to Safety Division Headquarters, Inspector Files Section. The applicant may contact his/her assigned Safety Division trooper or the local Safety Division Area Office after six months to reapply.
- C. Recertification.

1. Safety inspectors desiring to renew their inspector's license must participate in the recertification written examination. Inspectors arriving after the designated testing time are not eligible to participate in the written examination.
2. All safety inspectors are required to satisfactorily pass the appropriate examination for the license the inspector holds.
3. A safety inspector is not permitted to perform inspections after the expiration date of his/her inspector's license.
4. A safety inspector's license shall be valid for a period of three years.
5. All safety inspectors' licenses display an inspector's VSP number and do not display the social security number. The inspector's VSP number is written on the inspection sticker receipt or displayed on the automated MVIP receipt.
6. Safety inspector testing sites are not included on an inspection bulletin. Testing site information is updated in the computer system so that the usual letters going to inspectors to remind them of their upcoming recertification contain the updated information. All Safety Division Area Offices also have the updated information.
7. If the safety inspector has any questions about the testing sites, the safety inspector should contact the Safety Division Area Office closest to them. The office numbers are:

Area 61 (Richmond)	804-743-2217
Area 62 (Culpeper)	540-829-7414
Area 63 (Amherst)	434-946-7676
Area 64 (Wytheville)	276-228-6220
Area 65 (Waverly)	804-834-2386
Area 66 (Salem)	540-387-5437
Area 67 (Fairfax)	703-803-2622

- D. Vo-tech students who successfully complete the Vocational Automotive Mechanics Course and who are expected to graduate from the program with the required 1,080 hours and meet the requirements of the Department of State Police are certified as safety inspectors.
1. The vo-tech instructor contacts his/her assigned Safety Division trooper or the local Safety Division Area Office by March 15 of each year. The written examination is scheduled for students who are at least 18 years of age or who will be at least 18 years of age by March 31 of that year.
 2. The Safety Division troopers responsible for administering the written examinations at the vo-tech centers forward sufficient applications, Form SP-170B, for each student to complete prior to the testing date. A Criminal History Record Request (Form SP167) if the student is at least 18 years of age must also be completed. The Safety Division trooper indicates at the top of the Form SP-170B the name of the vo-tech school where the examination is given.
 3. The trooper verifies the notarizations and checks the driver's license for validity and identification of the applicant. If the applicant's driver's license is found to be expired, suspended, or revoked, the applicant is advised, and the application is destroyed. The applicant may reapply once the driver's license has been reissued or reinstated.

4. If the applicant successfully completes the written examination, the trooper notes at the end of Section I on the Form SP-170B the word "passed" and the date. The trooper signs the test and forwards it to Safety Division Headquarters, Inspector Files Section for further processing and investigation. Due to the age of these students, this should be done in a minimal amount of time.
5. If the applicant fails the test, failure is noted at the end of Section I on the Form SP170B with the word "failed" and the date.
 - a. The Safety Division trooper only administers one written examination at the votech center. Those students who fail the first written examination may retest, but not sooner than 30 days from the date of the last written examination. Those students who fail the first written examination keep the Form SP-170B in their possessions and present it to the Safety Division trooper at the test site prior to taking the second written examination.
 - b. The second written examination is not administered to the students prior to the end of the school year. Prior to taking the second written examination, the student shall have completed the Vocational Automotive Mechanics Course and must be employed at an official inspection station. These students are not required to have completed the one year of practical experience as an automotive mechanic.
 - c. For those students who pass the second written examination, the Safety Division trooper will forward the student's Form SP-170B to the Safety Division for further processing and investigation. Those students who successfully pass all phases for original certification are then issued an inspector license by the Safety Division trooper.
 - d. Students failing the second written examination are not allowed to test again for six months and must complete the application process as set forth for original certification.
6. The written examination consists of five sections: general information, brakes, suspension, lights, and glass. Each section contains 20 questions. A minimum score of 75% must be attained for each section.
7. Those students who successfully complete all phases of the written examination and background checks are then administered a practical examination. The Vo-tech instructor, who holds a valid Class A Safety Inspector's License, administers the practical "Class A" examination to each student who is expected to graduate from the program. The Safety Division trooper should be on hand to observe at least some of the practical examinations administered by the Vo-tech instructor to ensure that testing is administered according to Safety Division regulations.
8. Each student who successfully completes all phases for original certification by March 31 will be issued an inspector license by the Safety Division trooper, provided the student is at least 18 years of age. The Safety Division trooper will issue the original (white copy) to the inspector, forward the canary copy to Safety Division Headquarters, and retain the pink copy at the Safety Division Area Office for six months.
 - a. The vo-tech instructor is required to contact the Safety Division trooper prior to the end of the school year if any student fails to complete the Vocational Automotive Mechanics Course.

- b. Any student who fails to complete the Vocational Automotive Mechanics Course is not licensed as a certified safety inspector and is required to complete the application process as set forth for original certification.
- 9. Those students who will be at least 18 years of age after March 31 of that year and have successfully completed the Vocational Automotive Mechanics Course must contact the Safety Division trooper assigned to the inspection stations where they are employed and complete the application process as set forth for original certification. These students are not required to have completed the one year of practical experience as an automotive mechanic.

19VAC30-70-9.3. Reinstatement of safety inspector license; classification change; recertification.

- A. Reinstatement of safety inspector licenses following a period of suspension or revocation.
1. The inspector shall contact his/her supervising trooper or nearest Safety Division Area Office to initiate the reinstatement process.
 2. If the inspector is suspended for less than six months, the safety inspector's license will be held at the local Safety Division Area Office and returned upon the expiration of the suspension period. A check will be made by the supervising trooper with Department of Motor Vehicles (DMV) prior to reinstatement.
 3. Once a safety inspector's license has been suspended for a period of six months or more, regardless of the cause for suspension, no application Form SP-170B is required for reinstatement; however, Form SP-170D and Form SP-167 must be completed. The supervising trooper will conduct checks with DMV, all court jurisdictions, and the Central Criminal Records Exchange. The supervising trooper shall also review the inspector's history while in the inspection program to include the inspector's disciplinary record and a current credit report, which will be considered contingent upon reinstatement.
 4. If the suspended inspector's license expires during the suspension period, the inspector may complete the process for inspector recertification as set forth in this section. The trooper administering the test will retain all documentation. The inspector's license will be returned at the end of the suspension period, if the suspended inspector's records indicate they are suitable for reinstatement, and the appropriate documents forwarded to the Safety Division.
 5. Inspectors whose safety inspector's licenses have been revoked must complete the application process for initial certification as set forth in this section.
- B. Safety inspectors who desire to change their license classification must complete the written and practical examinations as outlined in 19VAC30-70-9.2.
- C. Safety inspectors desiring to renew their inspector's license must participate in the recertification process. The process requires the following:
1. Review of training materials as may be presented at the certification testing site by State Police personnel.
 2. Completion of the appropriate examination for the class license the inspector holds. A minimum score must be attained as previously outlined in 19VAC30-70-9.2.
 3. An inspector holding an expired license may be tested as long as his/her/her license has not been expired more than one month. During the period of expiration, they will not be permitted to perform inspections.

An inspector holding an expired inspector license that has not been expired more than one month and who fails the recertification examination the first time during this one month grace period may be retested one additional time not sooner than 30 days from the date of the last recertification examination. Inspectors failing this subsequent examination are not retested for six months and must complete the application process as set forth for initial certification.
- D. When a request for reinstatement is denied, inspectors who are suspended for a period of six months or more may not reapply sooner than 12 months from the date of the letter notifying the denial. Following an initial certification investigation for a revoked inspector, if the revoked inspector is denied, they may not reapply sooner than 12 months from the date of the letter notifying the denial.

Part II
Inspection Requirements

19VAC30-70-10. Official inspection station requirements.

- A. Official inspection stations, except private appointments, shall be open at least eight hours of each normal business day and shall be able to perform inspections 12 months throughout the year, except during illness of limited duration or normal vacation.
1. Normal business hours, Monday through Friday, are defined as an eight-hour period of time between 8 a.m. and 6 p.m.
 2. Stations are not prohibited from performing inspections at times other than during normal business hours.
 3. A station that advertises inspections beyond normal business hours shall be able to perform such inspections.
 4. If a station desires to maintain business hours that are different from those defined in this section, written permission must be obtained from the safety officer and a sign setting forth the inspection hours must be posted conspicuously at the station where it can be observed by a person desiring to have a vehicle inspected.
 5. Stations seeking to participate on a part-time basis, due to not having a full-time inspector available during normal business hours, shall be available for inspections for a minimum of 20 hours per week and shall notify their supervising trooper of the following items to have documented in their files:
 - a. Hours of operation the station will be conducting safety inspections.
 - b. Intended methods of notifying the public what hours inspections are available.
 - c. Name of the inspector who will be designated for part-time hours of operation.
 - d. Time period established for ownership to find and employ a full-time inspector.
- B. At least one full-time safety inspector (stations in compliance with subdivision A 5 of this section excluded), to perform inspections and one inspection lane meeting the minimum requirements shall be available for inspection at all times during the normal business day. All inspections must be made only at the locations and in the inspection lane approved by the Department of State Police. All stations shall have other lanes, bays, or areas in which repairs can be made so the inspection lane can remain available.
- The designated inspection areas, including any location where customers are permitted to enter when submitting vehicles for inspection, must be kept clean and free from excessive dirt, grease, and loose materials. If requested, customers presenting vehicles for inspection shall be allowed to observe the inspection process from a safe location designated by the station.
- C. Inspection station facilities must be properly maintained and must present a businesslike appearance to the general public. Property adjacent to the inspection station that is owned or controlled by the station must be free of debris, litter, used parts and junk vehicles. Vehicles properly contained within fenced storage areas shall be deemed to comply with this requirement.

- D. Official inspection stations may, at their discretion, accept vehicles on a first-come, first-served basis or by prescheduled appointments for the safety inspection of a motor vehicle pursuant to § 46.2-1157 of the Code of Virginia. Appointments shall be made for those motorists that are required by subdivision A 12 of § 46.2-1158.01 of the Code of Virginia.
- E. Safety inspectors, managers who supervise inspection activities, and business owners, through participation in the Official Motor Vehicle Inspection Program, are representatives of the Department of State Police and should conduct themselves in a manner to avoid controversy in dealing with customers presenting vehicles for inspection. The use of profanity or verbal abuse directed at customers presenting their vehicles for inspection will be grounds for suspension from participation in the inspection program and will be considered a Class IV offense as set forth in 19VAC30-70-6. Controversy that cannot be calmly resolved by the safety inspector, managers, and owners should be referred to the supervising trooper for handling.
- F. The “Certificate of Appointment” must be framed under glass or clear plastic and posted in the customer waiting area where it can be observed and read by a person submitting a vehicle for inspection.

Inspection stations must have garage liability insurance in the amount of at least \$500,000 with an approved surplus lines carrier or insurance company licensed to write such insurance in this Commonwealth. This requirement shall not apply to inspection stations that only inspect their company-owned, government-owned, or leased vehicles.

- G. The required “Official Inspection Procedure” sheet and the “Direct Inquiries” sheet furnished to each station must both be framed under glass or clear plastic and posted conspicuously in the customer waiting area where they can be observed and read by a person submitting a vehicle for inspection.
- H. The poster designating the station as an official inspection station shall be posted in a prominent location, outside or visible outside the station, to alert passersby that inspection services are available. Private inspection stations shall not display an outside poster.
- I. Each official inspection station shall display a list with the names and license expiration dates of each active inspector associated to the station within the Motor Vehicle Inspection Program (MVIP) system, adjacent to the certificate of appointment. All inspectors listed must be actively employed by the station.
- J. Important -- Any change in name, ownership or location of any official inspection station cancels the appointment of that station, and the Department of State Police must be notified immediately. The department shall be notified when an official inspection station discontinues operation.
- K. All inspection supplies, inspection binders and manual, unused stickers, duplicates of certificates issued, bulletins and other forms are the property of the Department of State Police and must be safeguarded against loss.
- L. Inspection supplies issued to an inspection station can be used only by that station and are not to be loaned or reissued to any other station.

1. Stations must maintain a sufficient supply of approval stickers, trailer and motorcycle approval stickers, rejection stickers and inserts. When reordering supplies, station owners or managers shall request sufficient supplies to sustain their business for approximately six months. However, it is realized that some stations will not be able to comply with the six-month requirement since there is a maximum of 2500 stickers per order limit. Also, when ordering supplies, the following information should be considered so the station does not order an excessive amount of supplies: each Car/Truck sheet of approval stickers contains 10 stickers, Car/Trunk month insert sheets contain 30 inserts each Trailer/Motorcycle sheet of stickers contains 10 stickers, Trailer/Motorcycle month inserts are 5 inserts per strip, and the rejection sticker sheet contains 10 stickers.

Stations are responsible for maintaining an adequate supply of inspections supplies to operate efficiently and without delay; therefore, after stations receive the first shipment of the calendar year, additional supplies shall be ordered through the MVIP station account.

2. Inspection stations that exhaust any type of their supplies, such as approval stickers, trailer and motorcycle approval stickers, rejection stickers, or inserts shall immediately stop all inspection operations and contact their supervising trooper or the nearest Safety Division Area Office.
- M. All losses of stickers must be reported immediately to the supervising inspection trooper or the nearest Safety Division Area Office.
- N. Every precaution against the loss of stickers must be taken. If the loss occurs through carelessness or neglect, a suspension of the station may result.
- O. The Official Motor Vehicle Safety Inspection Manual must be kept at or near the point of inspection for ready reference. Additional manuals, bulletins, regulations, and lists of approved equipment must also be available at all times. All reference materials may be kept in written or electronic form. Revisions to the Motor Vehicle Safety Inspection Manual will be sent to each station electronically through the MVIP system. Station management shall be responsible to see that each safety inspector is familiar with all bulletins and manual revisions and shall be required to furnish evidence to the department that all bulletins and manual revisions have been reviewed by each licensed inspector.

A copy of the diagram drawn by the investigating trooper, showing the approved inspection lane or lanes, will be maintained for review and kept available with the station's inspection supplies.

- P. Private appointment may be made of company stations or government stations that own and operate a minimum of 20 vehicles and they may inspect only company- owned or government-owned vehicles respectively. When authorized by the Department, they may inspect vehicles of a wholly-owned subsidiary or leased vehicles.
1. A private station may perform inspections during each month of the year or may elect to inspect only during certain designated months.
 2. A private station not electing to inspect vehicles every month of the year that finds it necessary to inspect a vehicle during a month other than those selected for inspection may issue a sticker to the vehicle from the nearest past inspection month.
- Q. All official inspection station owners, managers, and certified safety inspectors shall comply with the Virginia inspection laws and the inspection rules and regulations and will adhere to

all instructions given by the supervising trooper or the Safety Division. Reports of violations will be investigated and, if found to be valid, may result in the suspension of the station, suspension of the inspector, possible court action, or other appropriate action, or any combination of these actions. Repeated violations or serious violations may result in a revocation of the inspector or station appointment, or both, by the superintendent.

- R. The arrest of any person associated with the inspection program for a criminal offense of a nature that would tend to immediately reflect upon the integrity and reputation of the Department of State Police may be grounds for an inactive station status until final court disposition. Any finding other than acquittal may result in a suspension or revocation of the station's appointment.
- S. When a station has been suspended or revoked, it must release to an employee of the Department of State Police all inspection supplies, posters, and papers including the certificate of appointment. Failure to do so is a violation of §46.2-1172 of the Code of Virginia.
- T. The authority of the superintendent to suspend the designation or appointment of an official inspection station as provided in § 46.2-1163 of the Code of Virginia, or to suspend the certification of an inspector designated to perform inspections at an official inspection station, and, in keeping with the provisions of § 46.2-1166 of the Code of Virginia, is hereby delegated to any of the following supervisory ranks of the Department of State Police: Lieutenant Colonel, Major, Captain, Lieutenant, First Sergeant and Sergeant.
- U. Each station must purchase and keep in proper operating condition the following equipment: computer, printer, internet connection, paper hole punch, black ball point pen or pens or black marker or markers, sticker scraper with replacement razor blades, tire tread depth gauge, amp meter, headlight and auxiliary lamp adjustment tools, 12inch ruler, 25-foot measuring tape, torque wrench or torque sticks, brake pads/shoes/disc/drum measuring device, dial indicator, micrometer, pry bars, roller jack (at least 4-ton), and an approved type optical headlight aiming device. Each station that requests an additional inspection lane that is not in close proximity to the originally approved inspection lane must purchase an additional approved headlight machine for each lane that meets the minimum requirements. Stations are required to have one of the following headlight aiming devices: Hopkins Vision1, Hopkins Vision 100, American Aimers Vision 100, American Aimers Vision 2 Pro, or the Symtech (former L.E.T.), DVA-6, HBA-5, PLA-11, and PLA-12. This shall not apply to "trailer-only" inspection stations.

19VAC30-70-10.1. Official inspection station appointment.

- A. These procedures are applicable to the application process for initial appointment, reclassification of appointment, change in ownership, change in name, and reinstatement of the appointment for an official inspection station following a period of suspension or revocation.

For investigations involving changes to the original report, only those areas of inquiry that have changed need to be reported.

For changes in station name, tax ID, location, and classification only, a narrative report is not required. These requests may be reported on the Form SP-164. This report should include information pertinent to the change. A statement should be included to report verification of information contained in the station's new application for appointment.

1. Any garage or other facility that routinely performs motor vehicle, motorcycle, or trailer repairs may apply to the Department of State Police by contacting their Safety Division office for an application packet for appointment as an Official Safety Inspection Station:
 - a. The Department of State Police will forward an application package to the applicant.
 - b. The application forms are to be completed and returned to the supervising trooper processing the application within 45 days. Applicants who fail to return completed (Change of Ownership) applications within the 45-day time frame may be made temporarily inactive until the application is received by the Safety Division.
 - c. The application shall include the names, home addresses, personal email addresses, telephone numbers, dates of birth, and social security numbers for the applicant and each person who will supervise or otherwise participate in the program. Each person is also required to execute an Authorization for Release of Information Form (SP170-D) and a Criminal History Record Request (Form SP-167). When an owner with other established inspection stations is applying for an additional location, it shall not be necessary for the owner(s) to complete the Form SP-167 or undergo the usual background investigation. In these situations, the Department of State Police is only concerned with the personnel who will be responsible for handling and securing the safety inspection supplies.
2. Each inspection station application is reviewed, and the applicant must meet the following criteria:
 - a. The facility must have been in business at its present location for a minimum of 90 days.
 - 1) This requirement does not apply to a change in location for a previously appointed station.
 - 2) This requirement does not apply to a repair garage that is an established business and is expanding its mechanical convenience to the general public by the addition of other repair locations.
 - 3) This requirement does not apply to a business license as a franchised dealer of new vehicles.
 - b. The facility must perform motor vehicle, motorcycle, or trailer repairs routinely.

- c. The station must have on hand or be willing to purchase the necessary equipment as identified by the Department of State Police for performing safety inspections.
 - d. The station must employ or be willing to employ at least one safety inspector with the appropriate license for the desired station's classification.
 - e. The facility's physical plant must meet the specific standards for the station classification for which the appointment is required.
3. Each applicant station must undergo a background investigation to determine if the business and associated personnel meet the following minimum criteria:
- a. A review of the history of management and all persons employed who will participate in the inspection program must reflect general compliance with all federal, state, and local laws.
 - b. The character, attitude, knowledge of safety inspection requirements, mechanical ability, and experience of each individual who will perform or supervise safety inspections must be satisfactory.
 - c. The applicant and all participants must be familiar with and agree to comply with the Official Motor Vehicle Inspection Manual. Each vehicle presented for safety inspection must be inspected in strict compliance with the Code of Virginia and the Official Motor Vehicle Inspection Manual.
 - d. The business establishment must be financially stable. Its future existence should not be dependent upon appointment as an inspection station. The applicant and all persons to be associated with the inspection program must be in compliance with any judgment order or meeting all financial obligations, or both. The applicant and all persons to be associated with the inspection program must be in good financial standing for a period of at least one year.

Following any change in ownership, new ownership must show financial stability for a minimum of 90 days prior to their official inspection station appointment.

- 4. Each business must agree to provide the necessary space, equipment, and personnel to conduct inspections as required by the Department of State Police. Facilities and equipment must be maintained in a manner satisfactory to the superintendent. All safety inspectors must read and be thoroughly familiar with the instructions furnished for Official Inspection Stations and agree to abide by these instructions and to carefully inspect every motor vehicle, trailer, and semi-trailer presented for inspection as required by the Official Motor Vehicle Safety Inspection Manual. Businesses must operate inspection stations in strict accordance with the Code of Virginia and the Official Motor Vehicle Inspection Manual. The appointment of an inspection station may be canceled at any time by the superintendent and are automatically canceled if any change in address, name, or ownership is made without proper notification.
- 5. Any applicant whose application is voluntarily withdrawn, may not reapply sooner than six months from the date of the withdrawal. Any applicant whose application is denied may not reapply sooner than 12 months from the date of the letter notifying the denial.
- 6. Each business to be appointed will be assigned one of 11 classifications based upon the physical plant specifications or other criteria as follows:

- a. Unlimited: The inspection lane shall be level or on the same plane and in good condition for 60 feet. The front portion of the lane shall be level or on the same plane for a minimum of 40 feet. The entrance shall be at least 13-1/2 feet in height and no less than nine feet in width. Space should be adequate to allow a tractor truck towing a 53-foot trailer access to the inspection lane.
- b. Small exemption: The inspection lane shall be level or on the same plane for 40 feet. The entrance opening shall be at least 10 feet in height, eight feet in width, and adequate to accommodate vehicles 40 feet in length. Any vehicle exceeding 10 feet in height may be inspected if the building entrance will allow such vehicle to completely enter the designated inspection lane.
- c. Large exemption: The inspection lane shall be level or on the same plane and in good condition for 60 feet. The front portion of the lane shall be level or on the same plane for a minimum of 40 feet. The entrance shall be at least 13-1/2 feet in height and no less than nine feet in width. Space should be adequate to allow a tractor truck towing a 53-foot trailer access to the inspection lane. This classification is required to inspect only vehicles with a gross vehicle weight rating (GVWR) exceeding 10,000 pounds.
- d. Motorcycle: The inspection lane shall be level or on the same plane. The entrance shall be adequate to accommodate the motorcycle and the operator.
- e. Unlimited trailer: The inspection lane shall be reasonably level and in good condition for 60 feet. The entrance shall be at least 13-1/2 feet in height and no less than nine feet in width. This classification is required to inspect all trailers.
- f. Small trailer exemption: The inspection lane shall be reasonably level and in good condition for 40 feet. The entrance shall be at least 10 feet in height and adequate to accommodate trailers 40 feet in length. This classification is required to inspect only those trailers not exceeding 40 feet in length or 10 feet in height measured to the highest part of the trailer but not including racks, air conditioners, antennas, etc.
- g. Large trailer exemption: The inspection lane shall be reasonably level and in good condition for 60 feet. The entrance shall be at least 13-1/2 feet in height and adequate to accommodate all legal size trailers. This classification is required to inspect only property-carrying trailers exceeding 10 feet in height or 40 feet in length.
- h. Safety and emissions: The inspection lane shall be level or on the same plane. The lane must accommodate most passenger cars and light trucks. The emissions equipment must be placed in the lane at a location to allow the inspected vehicle to be positioned with all four wheels on the floor or on an above-ground ramp on a plane to the floor to accommodate headlight aiming and other required inspection procedures. Any above-ground structure must be constructed so as to permit proper steering, suspension, brake, and undercarriage inspection as outlined in the Official Motor Vehicle Safety Inspection Manual. A list of local inspection stations that can accommodate vehicles that cannot be safety inspected due to the pretenses of emissions equipment must be maintained and available for customers. A "bottle" jack or other appropriate lifting equipment may be used for safety inspection on above-ground structures.
- i. Private station: The inspection lane shall be level or on the same plane. The entrance and size must be adequate to accommodate any vehicle in the fleet. An applicant who owns and operates fewer than 20 vehicles will not be considered.

- j. Private station (fleet service contractor): The inspection lane shall be level or on the same plane. The entrance and size must be adequate to accommodate any vehicle in the fleet to be inspected. This classification will permit the inspection of all vehicles that the applicant has a written agreement to service and repair. An applicant who does not have at least six written agreements to service private fleets with at least five vehicles in each fleet or at least one written agreement to service a private fleet with at least 30 vehicles in the fleet will not be considered for this type of appointment. Vehicles not covered by a written agreement for service and repair, other than the vehicles owned by the applicant's company or corporation, shall not be inspected by a garage having this type of classification.
 - k. Private station (government): The inspection lane shall be level or on the same plane. The entrance and size must be adequate to accommodate any vehicle in the fleet to be inspected. This classification permits the inspection of all vehicles in the government entity's fleet, the fleet of any volunteer or paid fire department, or any other unit or agency of the government structure having a written agreement with such governmental entity for repair, inspection service, or both. An applicant for this classification must own or have a written agreement to inspect 30 or more vehicles. Vehicles not owned by or covered by a written agreement shall not be inspected by a garage having this type of classification.
- 7. Classifications listed in subdivisions 6 a through 6 h of this subsection must be open to the public and have at least one safety inspector available to perform inspections during normal business hours as set forth in 19VAC30-70-10.
 - 8. Private inspection station classifications may be assigned to businesses or governmental entities with fixed garage or repair facilities operating or contracting with vehicle fleets.
- B. A representative of any official inspection station may apply to the Department of State Police in writing to request a change of the station's status.
- 1. An application form is forwarded to the applicant.
 - 2. The applicant completes the application form and contacts the Department of State Police in keeping with the application instructions. Applications must include all data as set forth in this section.
 - 3. A Safety Division trooper is assigned to complete the appropriate investigation to affect the change. A change in status investigation includes the following:
 - a. A review of the existing station file.
 - b. An update of the file to include personnel, facility, or other significant changes. Criteria for appointment and background investigation procedures for a change in status will be in keeping with this section.
 - c. Official inspection stations are permitted to continue to perform safety inspections during a change of ownership investigation provided at least one safety inspector is employed that allows for continuous operation.
 - d. If disqualifying criteria is revealed, the station's appointment shall be canceled until final disposition of the application is made or until issues of disqualifying criteria are resolved.

- C. Once an official inspection station has been suspended, regardless of the cause for the suspension, management may request reinstatement up to 60 days prior to the expiration of the suspension period. Stations whose appointments are revoked may complete the application process as set forth for original appointments after the expiration of the period of revocation.
1. The applicant station must submit a letter to Safety Division Headquarters (Attention: Station Files) requesting reinstatement.
 2. An application package is forwarded to the applicant.
 3. The completed application forms must be returned to Safety Division Headquarters (Attention: Station Files).
 4. After review, the application package is forwarded to the appropriate Safety Division Area Office for investigation.
 - a. The trooper assigned to the investigation compares the information in the new application package to the information in the existing files.
 - b. The investigation focuses on any changes or inconsistencies, and the inspection station's history while in the inspection program, to include the station's disciplinary record.
 - c. The applicant station must meet all criteria for appointment as set forth in this section.
 - d. Any applicant whose application for reinstatement is rejected or voluntarily withdrawn may not reapply sooner than six months from the date of the withdrawal of the application.
- D. When a request for reinstatement is denied, a station suspended a period of six months or more may not reapply sooner than 12 months from the date of the letter notifying the denial. Following an original appointment investigation for a revoked station, if the revoked station is denied, it may not reapply sooner than 12 months from the date of the letter notifying the denial.

19VAC30-70-11. Automated Motor Vehicle Inspection Program (MVIP).

- A. The automated Motor Vehicle Inspection Program (MVIP) enables the Safety Division and inspection stations to efficiently record and retain data.
- B. Passwords or personal identification numbers (PINs) shall only be used by the person to whom they were assigned.
- C. Automated stations shall order all supplies via the MVIP system. Stations will ensure supplies are ordered no more than once per month.
- D. Once a certified safety inspector completes an inspection, they will be required to immediately enter the inspection information via the MVIP system. In the event there is an MVIP or internet connection failure, inspectors will complete the corresponding white and pink copy of the receipt provided for the approval or rejection stickers. A manual copy will be given to the customer or placed in the vehicle, while the original will remain with the station's records. Inspections performed during such outages shall be entered into MVIP by the inspector performing the inspections, and done so by the close of business of the day MVIP connectivity is restored.
- E. All stations and inspectors are required to verify the accuracy of the information entered through the MVIP system to include:
 - 1. One copy of the official safety inspection approval/rejection receipt shall be printed on 8-1/2 by 11-inch white paper and given to the customer or placed in the vehicle. The size of the print on the receipt shall not be reduced. In the event of MVIP or internet connection failure, the corresponding manual receipt from the book shall take the place of the MVIP generated receipt.
 - 2. The printed official inspection receipt number shall correspond with the issued decal.
 - 3. The complete vehicle identification number (VIN) shall be verified before submitting the inspection through the MVIP system and printing the official inspection receipt.
- F. When a station has a voided decal, it must be entered into MVIP by the inspector. Once entered, the receipt shall be printed, attached to the decal, and retained until the supervising trooper's next visit. The supervising trooper will be responsible for destroying the voided sticker and a Form SP-164 will not be required.
- G. Station management shall ensure that all stickers are accounted for, and all information has been entered correctly into the MVIP system. Completed approval/rejection records shall be retained by the station for a period of six (6) months. These records must be maintained on either the Safety Division provided log sheet; with the provided blank handwritten receipt (.pdf file); or point-of-sale/work order receipts that contain all required records of each inspection. Any deviations from these options for recording inspection data shall be approved and agreed with the supervising Trooper.
- H. At the end of the six-month period, used receipts shall be destroyed by burning or shredding. For the purposes of this Chapter, records shall include, for every sticker issued:

1. All identifying vehicle information (make, model, full VIN and license plate number if applicable)
2. All identifying sticker information (sticker serial number and month insert serial number for car/truck approval stickers)
3. The date the inspection is performed
4. The inspector's name and inspector number

19VAC30-70-20. General inspection requirements.

- A. Each official inspection station must inspect every vehicle presented for inspection as prescribed by this chapter, either approving or rejecting it. Inspections will not be performed unless requested.
1. Dealers' vehicles and out-of-state vehicles shall be inspected according to these standards when submitted for inspection. The dealer's name rather than the license number shall be shown on the rear of the approval or rejection sticker.
 2. When a vehicle is presented for inspection, the previous approval sticker, if any, on the vehicle shall be removed and destroyed before any inspection is conducted (except a rejection sticker). For purposes of the safety inspection program, "destroyed" shall mean that the previous inspection sticker will be disposed of in a manner so it cannot be reused or placed on another vehicle's windshield. After removing the inspection sticker, the safety inspector who is to perform the inspection must drive the vehicle into an approved inspection lane unless the safety inspector is not qualified to operate the vehicle. During the operation of the vehicle, the safety inspector must make application of the service and parking brakes and check for conditions as set forth in the Service Brake Section of the Official Motor Vehicle Safety Inspection Manual applicable to the vehicle being inspected.

WARNING: No razor blades or similar devices should be used to remove stickers from "Securiflex," "Anti-Lacerative" or "Inner Shield" type windshield. These windshields are identified as AS-14. Any questions concerning removal should be directed to the nearest Safety Division Area Office.
- B. Each inspection shall be a complete, uninterrupted inspection and shall include a check of all applicable items in the Official Motor Vehicle Safety Inspection Manual. All repair tools and testing equipment required prior to a station's appointment shall be properly maintained and available for use during each inspection.
- C. The term "inspection" as used in this chapter shall not include repairs or adjustments. Repairs or adjustments necessary to bring the vehicle in conformity with this chapter may be made by agreement between the owner and such station or whatever repair shop the owner may select. When requested to do so by the person submitting a vehicle for inspection, any repairs or adjustments necessary to bring the vehicle into compliance with the inspection program rules and regulations shall be made by the inspection station performing the inspection. The inspection station management may utilize the option of subcontracting the repairs or adjustments provided the application filed for the station appointment reflected that such repairs or adjustments will be subcontracted.
- D. Each vehicle that meets the requirements as set forth in this chapter shall be issued an approval sticker. Those vehicles that do not meet the inspection requirements shall be issued a rejection sticker. Any trailer required to be inspected under the provisions of the Code of Virginia may, only if the size or configuration of the trailer and the size and configuration of the facilities of the inspection station prevent the trailer from being inspected inside the inspection station, be inspected outside the inspection station. The

location on the outside of an inspection station where trailers may be inspected shall be approved by the Department of State Police and shown on the station diagram.

- E. Inspections may be made when it is raining or snowing. Care must be exercised when making inspections in inclement weather. Vehicles covered with ice, snow, mud or other debris to the extent that required parts cannot be inspected, may be refused inspection until the operator removes such debris.
- F. A certified safety inspector shall be prohibited from conducting safety inspection examinations on any vehicle registered to themselves. This restriction shall also apply to vehicles registered outside of the Commonwealth of Virginia.

19VAC30-70-25. Exceptions to motor vehicle inspection requirements.

- A. The following shall be exempt from inspection as required by § 46.2-1157 of the Code of Virginia:
1. Four-wheel vehicles weighing less than 500 pounds and having less than six horsepower;
 2. Boat, utility, or travel trailers that are not equipped with brakes;
 3. Antique motor vehicles or antique trailers as defined in § 46.2-100 of the Code of Virginia and licensed pursuant to § 46.2-730 of the Code of Virginia;
 4. Any motor vehicle, trailer, or semitrailer that is outside the Commonwealth at the time its inspection expires when operated by the most direct route to the owner's or operator's place of residence or the owner's legal place of business in the Commonwealth;
 5. A truck, tractor truck, trailer, or semitrailer for which the period fixed for inspection has expired while the vehicle was outside the Commonwealth (i) from a point outside the Commonwealth to the place where such vehicle is kept or garaged within the Commonwealth or (ii) to a destination within the Commonwealth where such vehicle will be (a) unloaded within 24 hours of entering the Commonwealth, (b) inspected within such 24-hour period, and (c) operated, after being unloaded, only to an inspection station or to the place where it is kept or garaged within the Commonwealth;
 6. New motor vehicles, new trailers, or new semitrailers may be operated upon the highways of Virginia for the purpose of delivery from the place of manufacture to the dealer's or distributor's designated place of business or between places of business if such manufacturer, dealer, or distributor has more than one place of business, without being inspected; dealers or distributors may take delivery and operate upon the highways of Virginia new motor vehicles, new trailers, or new semitrailers from another dealer or distributor provided a motor vehicle, trailer, or semitrailer shall not be considered new if driven upon the highways for any purpose other than the delivery of the vehicle;
 7. New motor vehicles, new trailers, or new semitrailers bearing a manufacturer's license may be operated for test purposes by the manufacturer without an inspection;
 8. Motor vehicles, trailers, or semitrailers may be operated for test purposes by a certified inspector without an inspection sticker during the performance of an official inspection;
 9. New motor vehicles, new trailers, or new semitrailers may be operated upon the highways of Virginia over the most direct route to a location for installation of a permanent body without being inspected;
 10. Motor vehicles, trailers, or semitrailers purchased outside the Commonwealth may be driven to the purchaser's place of residence or the dealer's or distributor's designated place of business without being inspected;
 11. Prior to purchase from auto auctions, motor vehicles, trailers, or semitrailers operated upon the highways not to exceed a 10-mile radius of such auction by prospective purchasers only for the purpose of road testing and motor vehicles, trailers, or semitrailers purchased from auto auctions operated upon the highways from such auction to (i) an official safety inspection station provided that (a) the inspection station is located between the auto auction and the purchaser's residence or place of business or within a 10-mile radius of such residence or business and (b) the vehicle is taken to the inspection station

on the same day the purchaser removes the vehicle from the auto auction or (ii) the purchaser's place of residence or business.

12. Motor vehicles, trailers, or semitrailers, after the expiration of a period fixed for the inspection thereof, may be operated over the most direct route between the place where such vehicle is kept or garaged and an official inspection station for the purpose of having the same inspected pursuant to a prior appointment with such station;
 13. Any vehicle for transporting well-drilling machinery and mobile equipment as defined in § 46.2-700 of the Code of Virginia;
 14. Motor vehicles being towed in a legal manner as exempted under § 46.2-1150 of the Code of Virginia;
 15. Logtrailers as exempted under § 46.2-1159 of the Code of Virginia;
 16. Motor vehicles designed or altered and used exclusively for racing or other exhibition purposes as exempted under § 46.2-1160 of the Code of Virginia;
 17. Any tow dolly or converter gear as defined in § 46.2-1119 of the Code of Virginia;
 18. A new motor vehicle, as defined in § 46.2-1500 of the Code of Virginia, that has been inspected in accordance with an inspection requirement of the manufacturer or distributor of the new motor vehicle (i.e., predelivery inspection (PDI)) by an employee who customarily performs such inspection on behalf of a motor vehicle dealer licensed pursuant to § 46.2-1508 of the Code of Virginia shall be deemed to have met the safety inspection requirements of this section without a separate safety inspection by an official inspection station. Such inspection shall be deemed to be the first inspection for the purpose of § 46.2-1158 of the Code of Virginia, and an inspection approval sticker furnished by the Department of State Police at the uniform price paid by all official inspection stations to the Department of State Police for an inspection approval sticker may be affixed to the vehicle as required by § 46.2-1163 of the Code of Virginia.

NOTE: Only an active certified safety inspector may enter the vehicle's information into the Motor Vehicle Inspection Program (MVIP) database and affix the inspection sticker to the vehicle (except predelivery inspections (PDIs) performed by employees designated by the station as outlined in 19VAC30-70-50, paragraph P);
 19. Mopeds;
 20. Low-speed vehicles; and
 21. Vehicles exempt from registration pursuant to Article 6 (§ 46.2-662 et seq.) of Chapter 6 of Title 46.2 of the Code of Virginia.
 22. Military surplus motor vehicles as defined in § 46.2-100 of the Code of Virginia and licensed pursuant to § 46.2-730.1 of the Code of Virginia
- B. The following shall be exempt from inspection as required by 46.2-1157 of the Code of Virginia provided (i) the commercial motor vehicle operates in interstate commerce; (ii) the commercial motor vehicle is found to meet the federal requirements for annual inspection through a self-inspection, a third-party inspection, a Commercial Vehicle Safety Alliance inspection, or a periodic inspection performed by any state with a program; (iii) the inspection has been determined by the Federal Motor Carrier Safety Administration to be comparable to or as effective as the requirements of 49 CFR 396.3(a); and (iv) documentation of such

determination as provided for in 49 CFR 396.3(b) is available for review by law-enforcement officials to verify that the inspection is current:

1. Any commercial motor vehicle operating in interstate commerce that is subject to the Federal Motor Carrier Safety Regulations.
2. Any trailer or semitrailer being operated in interstate commerce that is subject to the Federal Motor Carrier Safety Regulations.

19VAC30-70-40. Fees.

A. Before the inspection of a vehicle begins, the vehicle owner or operator must be informed there is a regulated fee pursuant to § 46.2-1167 of the Code of Virginia.

B. The maximum inspection fees effective July 1, 2019, are as follows:

\$51 for each inspection of any (i) tractor truck, (ii) truck that has a gross vehicle weight rating of 26,000 pounds or more, or (iii) motor vehicle that is used to transport passengers and has a seating capacity of more than 15 passengers, including the driver.

\$12 for each inspection of any motorcycle and autocycle.

\$20 for each inspection of any other vehicle, including trailers and motor homes.

1. Inspection fees will result in inspection stations retaining and forwarding \$0.70 to the Department of State Police to support the department's costs in administering the Motor Vehicle Inspection Program (MVIP). Collection of these fees will be billed quarterly to each station on April 1, July 1, October 1, and January 1 of each year.

<ul style="list-style-type: none">• Tractor Trucks• Trucks that have a gross vehicle weight rating of 26,000 pounds or more• Buses that seat more than 15 passengers (including the driver)	\$.50 per inspection
<ul style="list-style-type: none">• Cars• Pickup Trucks/Trucks• Recreational Motor Homes• Trailers	\$.70 per inspection
<ul style="list-style-type: none">• Motorcycles• Autocycles	\$2.00 per inspection

2. After the appropriate fee has been determined for each station, an invoice is uploaded to each station's billing account. The station has 30 days to submit payment by logging in to their respective eReceivables billing account.

NOTE: Late fees will be handled in accordance with §2.2-4805 and §6.2-302.

C. If a rejected vehicle is not submitted to the same station within the validity period of the rejection sticker or is submitted to another official inspection station, a complete inspection must be performed and a charge of \$51 may be made for inspection of tractor trucks, trucks that have a gross vehicle weight rating of 26,000 pounds or more, and buses that seat more than 15 passengers, including the driver. A charge of \$20 may be made for each inspection

performed on any other vehicle to include recreational motor homes and trailers. A charge of \$12 may be made for each motorcycle and autocycle inspection.

NOTE: The truck inspection fee does not pertain to any trailer.

- D. A charge of \$1.00 may be made for reinspection of a vehicle rejected by the same station during the 15-day validity of the rejection sticker.
- E. Inspection stations shall not charge an additional fee to those customers who drop off their vehicles for a state inspection. This is a violation of §46.2-1167 of the Code of Virginia unless the station charges a “storage fee” for all services and repairs and not just for inspections.

19VAC30-70-50. Approval stickers and decals.

- A. If the vehicle meets all inspection requirements, the certified safety inspector performing the inspection shall immediately enter the receipt information via the Motor Vehicle Inspection Program (MVIP) system.

The inspection sticker is not valid unless the rear portion is completed with the vehicle make, year built, license plate number (dealer name if a dealer tag is displayed), body type, and the complete vehicle identification number (VIN). The inspection sticker shall be completed using black indelible ink.

- B. Approval stickers and decals shall be issued according to the following schedule:

ANNUAL PROGRAM

Vehicles inspected in January are issued stickers bearing the Number "1"
Vehicles inspected in February are issued stickers bearing the Number "2"
Vehicles inspected in March are issued stickers bearing the Number "3"
Vehicles inspected in April are issued stickers bearing the Number "4"
Vehicles inspected in May are issued stickers bearing the Number "5"
Vehicles inspected in June are issued stickers bearing the Number "6"
Vehicles inspected in July are issued stickers bearing the Number "7"
Vehicles inspected in August are issued stickers bearing the Number "8"
Vehicles inspected in September are issued stickers bearing the Number "9"
Vehicles inspected in October are issued stickers bearing the Number "10"
Vehicles inspected in November are issued stickers bearing the Number "11"
Vehicles inspected in December are issued stickers bearing the Number "12"

All issued annual inspection stickers shall expire at the end of the last day of the month displayed on the sticker. For example, a January inspection sticker expires at 12:00:00 a.m. on February 1.

All February annual inspection stickers (i.e., stickers numbered "2") due to expire at midnight, February 28 automatically will be valid through midnight February 29 each leap year.

- C. The numeral insert indicating the month of expiration shall be affixed to the box identified as month on the car or truck approval sticker. The numeral insert indicating the month of expiration shall be affixed to the box identified as month on the trailer or motorcycle sticker.

Extreme care should be used by inspectors when applying inserts. The sticker shall be placed at the bottom left corner of the windshield when viewed from the inside of the vehicle. The left edge of the sticker is to be placed as close as practical, but no closer than one inch to the left edge of the windshield when viewed from the inside of the vehicle. The top edge of the sticker is to be approximately four inches from the bottom of the windshield when viewed from the inside of the vehicle.

NOTE: Minor adjustments to the placement of the safety inspection sticker may be made to avoid the decal being obscured by the windshield's monogram.

NOTE: On passenger vehicles not equipped with a windshield, the sticker shall be placed on or under the dash and protected in some manner from the weather.

EXCEPTIONS: On vehicles equipped with heating and grid elements on the inside of the windshield, the sticker shall be placed one inch above the top of the grid element and the left edge of the sticker shall be approximately one inch to the right of the left edge of the windshield when viewed from the inside of the vehicle.

Any sticker or decal required by the laws of any other state or the District of Columbia and displayed upon the windshield of a vehicle submitted for inspection in the Commonwealth is permitted by the superintendent, provided the vehicle is currently registered in that jurisdiction, and the sticker is displayed in a manner designated by the issuing authority and has not expired. In these cases, if the sticker or decal is located where the inspection sticker is to be placed, it will not be removed unless the owner or operator authorizes its removal. The inspection sticker will be placed 1/4 inch to the right of the sticker or decal when viewed from the inside of the vehicle without removing or overlapping the sticker or decal.

D. The Code of Virginia requires that the inspection sticker be displayed on the windshield or at other designated places at all times. The inspection sticker cannot be transferred from one vehicle to another.

EXCEPTION: If the windshield in a vehicle is replaced, a valid sticker may be removed from the old windshield and placed on the new windshield.

E. The sticker issued to a motorcycle shall be affixed to the left side of the cycle where it will be most visible after mounting. The sticker may be placed on a plate on the left side where it will be most visible and securely fastened to the motorcycle for the purpose of displaying the sticker. The sticker may be placed horizontally or vertically.

F. Trailer stickers will be issued to all trailers and semitrailers required to be inspected. (No boat, utility, or travel trailer that is not equipped with brakes shall be required to be inspected.)

G. All inspected trailers must display a trailer sticker on that particular vehicle. These stickers are to be placed on the left side of the trailer near the front corner. The sticker must be affixed to the trailer body or frame. In those instances where a metal back container with a removable transparent cover has been permanently affixed to the trailer body, the sticker may be glued to it. The container must be permanently mounted in such a manner that the sticker must be destroyed to remove it.

H. In all other cases involving unusually designed trailers such as pole trailers, the safety inspector is to exercise his/her own good judgment in placing the sticker at a point where it will be as prominent as possible and visible for examination from the left side.

I. Motorcycle and Trailer stickers are combined into a single orange sticker, beginning with the prefix AA. The trailer and motorcycle receipts are completed in the same manner as other inspection receipts.

Appointed stations will keep sufficient inspection supplies on hand to meet their needs. Requests for additional supplies shall be ordered via the MVIP system. Requests for supplies that are to be picked up at the Safety Division Headquarters must be made at least 24 hours prior to pick up.

J. Packing slips mailed with inspection supplies will be kept on file at the station for at least 24 months.

- K. All unused center inserts used to indicate the month that a sticker expires, in possession of the inspection station at the end of each month, shall be retained by the inspection station, properly safeguarded, and used in the inspection of vehicles for that particular month in the following year or be disposed of as directed by the Department of State Police.

All inspection supplies that are voided, damaged, disfigured or become unserviceable in any manner, will be returned to the Safety Division. New replacement supplies will be issued to the station. Expired stickers will be picked up by the station's supervising trooper.

- L. All voided approval or rejection stickers will be picked up by the station's supervising trooper.
- M. The MVIP system approval or rejection printed receipt shall be given to the owner or operator of the vehicle. In the event of an MVIP or internet connection failure, manual receipts from the approval and rejection stickers shall be issued to the customers.
- N. All records for the approval (car and truck, trailer and motorcycle) and rejection stickers shall be retained and kept on file at the station for at least six months. Stations shall notate necessary information in their records as outlined in 19VAC30-70-11 paragraph H to provide a means of tracking for audit purposes. They may be inspected by any law-enforcement officer during normal business hours.
- O. Safety Division troopers may replace inspection stickers that have separated from the windshield of motor vehicles and become lost or damaged without conducting an inspection of the safety components of the vehicle. Such replacement of inspection stickers shall be made only in accordance with the following provisions:
 - 1. A vehicle owner or operator complaining of the loss or damage to the inspection sticker on the windshield of their vehicle due to separation of the sticker from the windshield shall be directed to the nearest Safety Division Area Office or Safety Division trooper.
 - 2. Safety Division troopers, upon receipt of a complaint from a vehicle owner or operator that their inspection sticker has been stolen, lost or become damaged due to separation from the windshield, will make arrangements to meet the person to effect the replacement of the sticker. A vehicle owner or operator alleging theft of the inspection sticker will furnish proof to the Safety Division trooper that such theft has been reported to the proper law-enforcement authority.
 - 3. The vehicle owner or operator must produce the original safety inspection approval sticker receipt indicating a valid approval inspection sticker was issued to the vehicle within the past 11 months. (The vehicle must be reinspected if the expiration of the original inspection sticker is in the month the request is being made.)
 - 4. The Safety Division trooper will verify by the inspection receipt that the vehicle was issued an approval inspection sticker within the past 11 months and will then issue a replacement inspection sticker to the vehicle. If any obvious equipment defects are detected during the replacement process, the vehicle will not be issued a replacement approval sticker.
 - 5. The Safety Division trooper will complete the inspection sticker receipt for the approval sticker from information contained on the original receipt. The date the replacement sticker is issued will be used in the date space. In the space for Inspection Related Charges, the trooper will insert the word "REPLACEMENT" and the sticker number from the original inspection receipt.

6. The Safety Division trooper will sign the receipt vertically in the O.K. column in the "Equipment Inspected" blocks. These blocks will not otherwise be completed.
 7. The Safety Division trooper shall place month and year inserts on the inspection sticker to reflect the expiration as shown on the original approval inspection sticker and place the inspection sticker on the windshield in accordance with the requirements of subsection C of this section.
 8. The Safety Division trooper will enter the replacement information into the MVIP system.
- P. New vehicle safety inspections.
1. Section 46.2-1158.01 of the Code of Virginia allows an employee who customarily performs the inspection requirement of a manufacturer or distributor of new motor vehicles to place an inspection sticker furnished by the Department of State Police on the vehicle once it has met the requirements of that manufacturer or distributor. This employee does not have to be a certified safety inspector.
 2. With the addition of other personnel using Department of State Police inspection supplies, a system shall be developed at each inspection station to afford accountability of all supplies. The system shall include proper safeguards to prevent the loss of supplies through carelessness, neglect, theft, or unauthorized use.
 3. Inspection stations shall not mix annual state inspections with predelivery inspections (PDI) in the same supply of inspection stickers.
 4. All employees shall be reminded that anyone who performs inspections, whether it be for the annual inspection or the PDI inspection, is subject to criminal prosecution if inspection supplies are used illegally or used in some other unauthorized way.
 5. Station management and licensed safety inspectors are subject to administrative sanctions for any misuse of inspection supplies.
 6. The inspection receipts shall be completed as usual with the following exceptions: On the "inspector" line, the initials "PDI" (for predelivery inspection) and the printed employee's name performing the inspection shall be entered. On the "inspector's license number" line, the letters "N/A" shall be entered. In the equipment inspected section, the words "New Vehicle" shall be entered in the "adjust" column. The PDI employee performing the inspection shall sign his/her name in the "O.K." column.

19VAC30-70-60. Rejection stickers.

- A. Only one rejection sticker shall be issued to any one vehicle. A rejection sticker shall not be issued to any vehicle already bearing such a sticker or to one which bears evidence of previously being issued a rejection sticker. When a vehicle is bearing a valid or expired rejection sticker, it is not to be removed unless the vehicle meets all of the inspection requirements.
- B. A vehicle rejected by one station may be reinspected by another station if the owner desires to have this done; however, that station shall perform a complete inspection of the vehicle.
- C. Reinspection of a rejected vehicle by the same station during the 15-day validity of the rejection sticker need include only a check of the items previously found defective, unless there is an obvious equipment defect that would warrant further rejection of the vehicle. Such reinspection will not constitute a complete inspection and a \$1.00 fee may be charged. Furthermore, if a vehicle returns for reinspection within the 15-day period, the rejecting station will reinspect the vehicle without delay or at the reasonable conclusion of the current inspection being performed.
 - 1. If additional defects are detected during reinspection of a vehicle previously rejected, the vehicle will not be issued an approval sticker.
 - 2. No vehicle bearing a valid rejection sticker shall be entitled to receive more than two reinspections by the rejecting station during the validity period of the rejection sticker.
 - 3. The validity period of the rejection sticker shall be 15 days in addition to the day of inspection.
 - 4. Any vehicle that is presented for inspection at another inspection station after the 15day validity period, if the vehicle was rejected for brakes, and the inspector cannot determine which wheels were checked, then all four wheels will be removed to ensure that all repairs or defects have been corrected.
- D. If repairs are to be made to a rejected vehicle that would necessitate removing the vehicle from the inspection lane, no rejection sticker need be issued; however, the vehicle must be returned to an approved lane for a recheck of the rejected items and the application of the approval sticker.
- E. If the vehicle does not meet all the requirements and the owner does not authorize immediate repairs, and if a rejection sticker has not already been issued, a rejection sticker shall be legibly filled out in its entirety with a black ball point pen. The certified safety inspector performing the inspection shall immediately enter the receipt information via the MVIP system. The complete vehicle identification number (VIN), tag number or car dealer name if a dealer tag is attached, mileage, year, make, and model shall be included. A circle to indicate which wheels were pulled to check the brakes and an individual mark shall be placed in each equipment block of the rejection sticker that was pertinent to the rejection. In addition, information may be written on any blank area as to the exact nature of the rejection (i.e., front brakes vs. rear brakes). The date of issue shall be punched, and the sticker affixed to the same location as indicated in subsections C, E, and G of 19VAC30-70-50. (When affixed to a trailer or motorcycle, the face of the rejection sticker shall be attached to the trailer or motorcycle in order to allow the rejection data on the back side to be read.)

- F. The operator of the rejected vehicle shall be informed of the following:
1. The rejection sticker is valid for 15 days in addition to the date of inspection.
 2. The rejection sticker places no travel restriction on the operation of the vehicle and is issued in lieu of an approval sticker.
 3. The vehicle operator is legally responsible for any defect if operated on the highway and may be subject to a traffic summons for any existing equipment violation.
- G. All receipt copies of rejection stickers will be retained in the books and shall be kept on file at the station for at least (6) months. They may be inspected by any law-enforcement officer during normal business hours.

Part III
Inspection Requirements for Passenger Vehicles
and Vehicles Up to 10,000 Pounds (GVWR)

19VAC30-70-80. Service brakes.

- A. The inspector, as a minimum, must drive all vehicles into the inspection lane and test both service and parking brakes.
- B. A minimum of two wheels, one front and one rear, must be inspected on each passenger and multipurpose vehicle with a gross vehicle weight rating of 10,000 pounds gross vehicle weight rating (GVWR) or less at the time of inspection, except those listed in subdivisions 1, 2, and 3 of this subsection.

NOTE: If the vehicle is equipped with wheels that do not allow visual access to the braking system, the inspected wheels shall be removed.

NOTE: If the vehicle is equipped with drum brakes, the wheel and drum shall be removed for inspection.

- 1. Motorcycles.
- 2. A new model vehicle is defined as a vehicle that has not been titled or leased and is less than one year old, measured from October 1 as of each year; if such motor vehicle does not have a model year, such measurement shall be made from the date of manufacture.
- 3. Trucks with floating axles that require seal replacement upon removal of rear wheels. The inspection receipt (approval and rejection) shall be marked to reflect which wheels were pulled.

Warning: If wheels are removed to inspect brakes, lug nuts must be torqued to the manufacturer's specifications to prevent damage to disc rotors. The use of an impact wrench may exceed the manufacturer's specifications and damage disc rotors.

- C. If any braking problem is detected, the inspector may test drive or require a test drive of the vehicle.
- D. Inspect for and reject if:
 - 1. Vehicle is not equipped with brakes or any brake has been disconnected, rendered inoperative, or improperly installed. Trailers having an actual gross weight of less than 3,000 pounds are not required to be equipped with brakes; however, if brakes are installed, these vehicles must be inspected.

Brake System Failure Indicator Lamp

- 2. Passenger vehicles manufactured after January 1, 1968, are not equipped with a red brake failure warning lamp or warning lamp does not light with parking brake applied when ignition key is turned to the start position, except for anti-lock system. The red brake failure warning lamp should light when the ignition key is turned to the start position; on some imports it may be checked when the emergency brake is applied or other factory installed test button. (DO NOT reject if only the amber ABS/anti-lock brake lamp is on.) With the engine running and parking brake released, the red brake failure warning lamp should go off, except for vehicles equipped with anti-lock system. If so, apply service brake for 10 seconds and if the red brake failure warning lamp lights again the system is defective. Also, if the warning lamp light does not come on when there is a leak or the warning lamp light is not functioning properly, the system is defective and shall be rejected. NOTE: This subdivision does not apply to vehicles registered as street rods nor does it imply that the red brake failure warning lamp needs to light when the emergency

brake is set. There are many vehicles that are not factory equipped with an emergency brake indicator light.

Note: Vehicles equipped with a brake pad wear indicator warning light shall not constitute an automatic rejection for the vehicle submitted for a safety inspection. Each vehicle manufacturer has determined an appropriate level to activate the brake pad wear indicator warning light; therefore, it shall be the responsibility of the inspector to confirm whether or not the brake pads have exceeded the established tolerance of 2/32 of an inch.

Brake Linings and Disc Pads

3. Bonded, molded or riveted linings or disc pads are worn to less than 2/32 of an inch in thickness at any point (not to include manufactured slots), or over the rivet heads.
4. Wire in wire-backed lining is visible in friction surface.
5. Snap-on brake linings are loose.
6. Any lining is broken or cracked so that the lining or parts of the lining are not firmly attached to the shoe or has cracks on the friction surface extending to the open edge.
7. Grease or other contamination is present on the linings, drums, or rotors.
8. Rivets in riveted linings are loose or missing.
9. Any lining or pad is misaligned or does not make full contact with the drum or rotor with the exception of minor scoring caused by debris, provided it does not affect braking efficiency.
10. Any foreign material or debris caught between a drum or rotor and the brake pad.

Brake Drums and Discs

NOTE: The inspector shall ensure that the minimum measurements in subdivision D 3 of this section are obtained.

11. Brake drums or brake discs (rotors) are worn or scored to the extent that their machining would result in a failure to meet manufacturer's specifications. Use the specification stamped on the rotor or drum if available.
12. Brake drums or brake discs (rotors) are scored to the extent that the braking surface is reduced to the point that the braking efficiency is adversely affected. This does not apply to minor scoring caused by debris.

NOTE: A number of vehicles on the market are equipped with a lock nut to hold the rear brake drum in place. Manufacturers recommend replacement of these lock nuts after each removal to prevent failure of the component. If the customer is advised up front, then the wholesale cost of the replacement nut may be charged to the customer.

NOTE: The proper method to remove the rear brake assembly on the 2000 Ford Focus is to remove the four bolts from the opposite side of the assembly. Removal otherwise may damage the outside grease cap and incur a cost to replace.

13. Brake drums or discs have any external crack or cracks more than one half the width of the friction surface of the drum or disc. NOTE: Do not confuse short hairline heat cracks with flexural cracks.

Mechanical Linkage

14. Cables are frayed or frozen.
15. Mechanical parts missing, broken, badly worn, or misaligned.

E. Hydraulic.

NOTE: Some motor vehicles, beginning with 1976 models, have a hydraulic power system that serves both the power-assisted brakes and power-assisted steering system. Some vehicles, beginning with 1985 models, have an integrated hydraulic actuation and anti-lock brake unit using only brake fluid.

1. Brake hydraulic system. Inspector should check the brake hydraulic system in the following manner: test vehicle in a standing position; apply moderate pressure to the brake pedal for 10 seconds. Brake pedal height must be maintained. On vehicles equipped with power-assisted systems, the engine should be running.
2. Hydraulic system operation. Stop engine, then depress brake pedal several times to eliminate all pressure. Depress pedal with a light foot-force (30 pounds). While maintaining this force on the pedal, start engine and observe if pedal moves slightly when engine starts.

Reject vehicle if pedal does not move slightly as engine is started while force is on brake pedal.

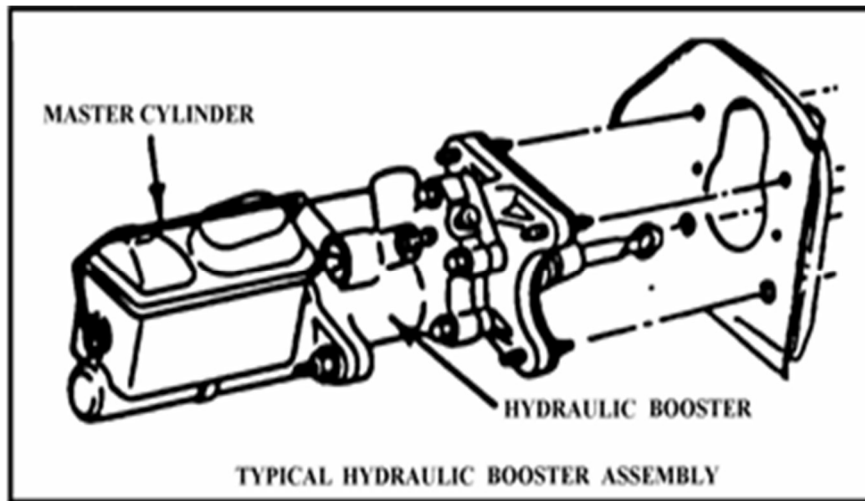

3. Condition of hydraulic booster power brake system. Inspect system for fluid level and leaks.

Reject vehicle if there is insufficient fluid in the reservoir; if there are broken, kinked or restricted fluid lines or hoses; if there is any leakage of fluid at the pump, steering gear or brake booster, or any of the lines or hoses in the system; or if belts are frayed, cracked or excessively worn.

4. Integrated hydraulic booster/anti-lock system operation. With the ignition key in the off position, depress brake pedal a minimum of 25 times to deplete all residual stored pressure in the accumulator. Depress pedal with a light foot-force (25 pounds). Place ignition key in the on position and allow 60 seconds for the brake warning light to go out and the electric pump to shut off.

Reject vehicle if the brake pedal does not move down slightly as the pump builds pressure or if the brake and anti-lock warning lights remain on longer than 60 seconds.

NOTE: The inspection of the ABS light is only for an integrated system that is an earlier system. The newer system that has the nonintegrated systems does not need to be checked. If the ABS system malfunctions on the newer system, the brake systems are still functional.

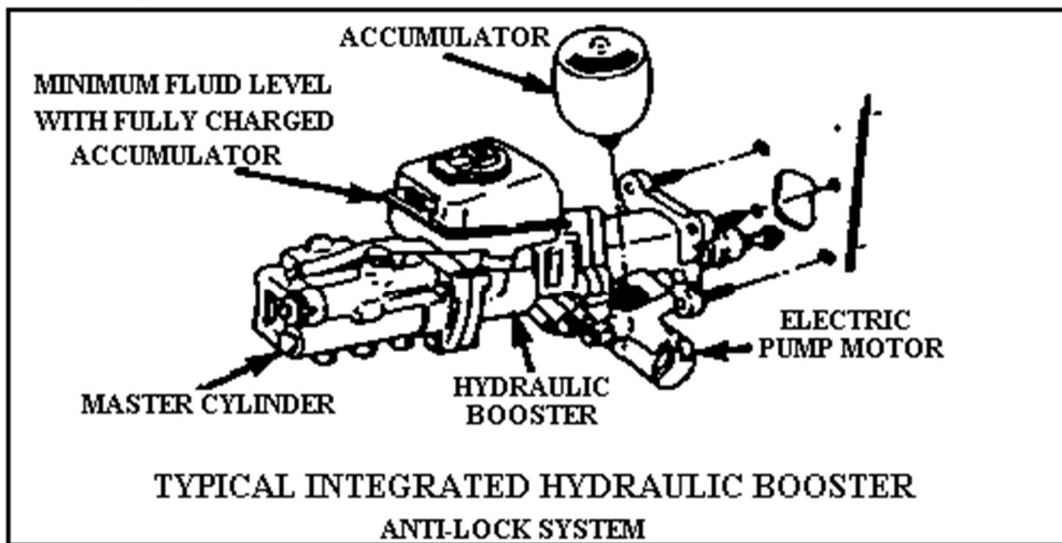

5. Condition of integrated hydraulic booster/anti-lock system with electronic pump. With the system fully charged, inspect system for fluid level and leaks.

Reject vehicle if there is insufficient fluid in the reservoir; if there are broken, kinked or restricted fluid lines or hoses; or if there is any leakage of fluid at the pump or brake booster, or any of the lines or hoses in the system.

6. Vacuum system operation. Stop engine then depress brake pedal several times to eliminate all vacuum in the system. Depress pedal with a light foot-force (25 pounds). While maintaining this force on the pedal, start engine and observe if pedal moves down slightly when engine starts.

Reject vehicle if pedal does not move down slightly as engine is started while force is on the brake pedal. In full vacuum-equipped vehicles, there is insufficient vacuum reserve for one full service brake application after engine is stopped.

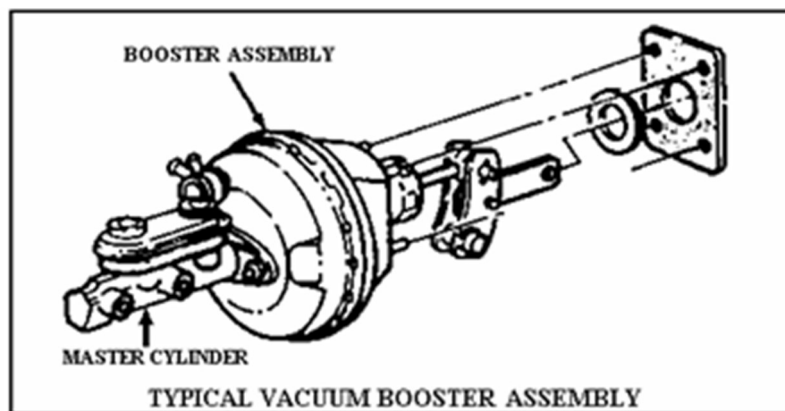

7. Condition of vacuum booster power brake system. Reject vehicle if there are collapsed, cracked, broken, badly chafed or improperly supported hoses and tubes, loose or broken hose clamps.

F. Inspect for and reject if:

General Specifications - Hydraulic Brakes

1. There is any leakage in the master cylinder, wheel cylinders, or brake calipers. When checking for leakage in rear wheel cylinders, do not disturb the dust boot.

NOTE: Do not reject for the common dust ball formed on wheel cylinders or for wetness that may have spread to the backing plate unless it has contaminated the linings or drums as specified in subdivision D 8 of this section. Consumers should be advised of this wear so that they will be aware that repair may be needed before their next inspection. This may not warrant an immediate repair considering the dual valve master cylinder.

2. Fluid level in master cylinder is below the proper level for the particular vehicle.
3. There is any evidence of a caliper sticking or binding.

Electric Brake System

4. Trailers show an amperage value more than 20% above or 30% below the brake manufacturer's maximum current rating for each brake.
5. Amp meter shows no reading or indicator is not steady on application and release of brake controller.
6. Any terminal connections are loose or dirty; wires are broken, frayed, or unsupported; any single conductor non-stranded wires below the size recommended by the brake manufacturers are installed.
7. Electrical trailer brakes do not apply automatically when the breakaway safety switch is operated.
8. Breakaway braking devices are missing or inoperative; cable is frayed or broken.

General Specifications

9. Absence of braking action on any wheel required to have brakes.
10. There is any leakage in any hydraulic, air, or vacuum lines; hoses have any cracks, crimps, or restrictions or are abraded, exposing inner fabric; tubing or connections leak or are crimped, restricted, cracked, or broken; or any valves leak or are inoperative.
 - a. Reject the vehicle if the brake hoses or tubing are stretched or extended and do not allow for suspension movement.
 - b. Brake tubing and hoses must be:
 - 1) Long and flexible enough to accommodate without damage all normal motions of the parts to which they are attached;
 - 2) Secured against chaffing, kinking, or other mechanical damage; and
 - 3) Installed in a manner that prevents them from contacting the vehicle's exhaust system or any other source of high temperatures.
11. Any hydraulic brake tubing has been repaired using a compression fitting.
12. Brakes are not equalized so as to stop the vehicle on a straight line.
13. There is less than 1/5 reserve in actuator travel of the service brake when fully applied on all hydraulic, mechanical, or power-assisted hydraulic braking systems.
14. When tested on dry, hard, approximately level road free from loose material, at a speed of 20 miles per hour without leaving a 12-foot wide lane, results in excess of the following distances are obtained:

(When in doubt about a vehicle's stopping ability, the inspector shall conduct a road test.)

 - a. Any motor vehicle (except motorcycles, trucks, and tractor-trucks with semitrailers attached) four wheel brakes - 25 feet.

- b. Any motor vehicle (except motorcycles, trucks, and tractor-trucks with semitrailers attached) two wheel brakes - 45 feet.
- c. All combinations of vehicles - 40 feet.

19VAC30-70-90. Brakes: emergency, parking, or holding; batteries.

- A. Some vehicles are equipped with an actual emergency brake, while others have only a parking or holding brake. Some types may be actuated by a foot or hand lever, while others may incorporate a switch or valve to actuate the brake. Air and vacuum brake systems may employ spring activating parking brakes.
- B. Inspect for and reject if:
1. Vehicle or combination of vehicles is not equipped with a parking, holding, or emergency brake in good working order of the type installed as original standard factory equipment for the vehicle on which it is installed.
 2. The parking brake actuating mechanism does not fully release when the control is operated to the off position or if the parking brake lamp light remains on.

NOTE: The light does not apply to vehicles that are not equipped with a parking (emergency) brake indicator light.

3. Any mechanical parts are missing, broken, badly worn, or are inoperative.
4. Cables are stretched, worn, or frayed or not operating freely.
5. Grease or similar-type contamination is present on the linings, drums, or rotors.
6. Parking brake will not hold the vehicle stationary with the engine running at slightly accelerated speed with shift lever in drive position for automatic transmission or shift lever in low gear with clutch engaged for standard shift transmission.
7. Holding brake will not disengage when engine is started and vehicle is placed in drive. Holding brake will not hold vehicle stationary with foot on holding brake and vehicle in drive.
8. On vehicles equipped with automatic transmissions, the vehicle will start in any gear other than (P) park and (N) neutral. If the gearshift indicator does not identify the park (P) and neutral (N) positions, then the vehicle shall be rejected.
9. On vehicles equipped with manual transmissions, the vehicle will start in any gear if the clutch is not depressed or disengaged.

NOTE: This will not apply to older model vehicles, which were not originally equipped with a neutral-safety switch, clutch disengagement system or clutch pedal position sensor by the manufacturer.

10. The accelerator does not disengage after being depressed, allowing the engine to return to a normal idle speed.

19VAC30-70-100. Brakes: trailer (GVWR less than 10,000 pounds).

Inspect for and reject if:

1. Trailer brakes do not comply with 19VAC30-70-80 and 19VAC30-70-90.
2. Operator does not have full control over brakes. For the purpose of this subdivision, surge brakes are considered to be in control of the operator.
3. Breakaway braking devices are missing or inoperative or cable is frayed or broken, or trailers, manufactured or assembled after January 1, 1964, having an actual gross weight of 3,000 pounds or more are not equipped with emergency breakaway brakes designed to:
 - a. Apply automatically upon breakaway from towing vehicle.
 - b. Remain fully applied for at least 15 minutes.
 - c. Apply and release by operation of the manual emergency control.

A minimum of one wheel must be removed from each axle equipped with brakes to inspect the brake components.

NOTE: Trailers having an actual gross weight of 3,000 pounds or more, but with a manufacturer's gross weight rating of less than 10,000 pounds, need not be equipped with brakes on all wheels.

- a. Exception: Wheels on trailers equipped with open brake mechanisms are not required to be removed.
- b. The inspection receipt approval and rejection shall be marked to reflect which wheel, drum, or dust cover was removed or inspected.

19VAC30-70-110. Steering and suspension.

A. The steering and suspension systems installed and utilized on motor vehicles have evolved to where many different suspension systems are being designed, developed, and employed on vehicles. To properly inspect the steering and suspension on vehicles, it may be necessary for the inspection to be made in accordance with manufacturer's recommended procedures in addition to meeting any requirements outlined in this regulation.

B. Inspect for and reject if:

1. Any modification has been made that affects normal functioning of the shock absorbers. The inspector should operate the vehicle when in doubt. (If there is no evidence of the convolutions (coils) of the spring hitting one another, one pair (two) of nonmetallic coil spring stabilizers may be present in each of a vehicle's front coil springs, provided the installation of the stabilizers does not cause the springs to be higher than their original height.)

Shock absorbers in fully extended or compressed positions when the vehicle is stationary will not function normally.

2. The front end suspension has been modified by the use of lift blocks. (A lift block is defined as any solid piece of wood, metal, or other material placed between and separating the vehicle's front axle and the springs.) This does not prohibit the use of shims that may be necessary to correct front end alignment.
3. Any modification has been made to the front end suspension which reduces turning radius, bypasses safety components of original steering mechanism or if there is any lateral movement between the axle and frame.

4. Any modification has been made to the suspension to cause the vehicle body or chassis to come in contact with the ground or expose the fuel tank to damage from collision.

Reject the vehicle if it has been modified by any means so as to raise its body more than three inches above the manufacturer's attachment points or the frame rail (exclude original manufacturer's spacers, washers or bushings when measuring).

5. Any modification has been made to cause the wheels to come in contact with the body or frame under normal operating conditions.
6. A motor vehicle has a repair kit or preventive maintenance kit installed on a tie rod end, idler arm, ball joint, or any other part of the vehicle's steering gear.

NOTE: The repair kit or preventive maintenance kit usually consists of a small coil spring and a plastic cap that is placed over the bolt stud of the component and held in place by a retaining nut. There is nothing in this paragraph that prohibits the replacement of parts or components of a motor vehicle's steering gear in order to correct deficiencies in the steering gear.

7. When checked visually, the wheels appear to be out of line or an axle is bent.
8. Any vehicle that shimmies or wanders at normal operating speeds.
9. Rack and pinion steering bellows (boot) is defective or missing. Do not inspect constant-velocity (CV) boots, CV joints, or universal joints on rear wheel drive vehicles.

NOTE: CV boots on the vehicle shall not be rejected if the CV boots are defective or missing.

10. Power steering is defective and affects adequate steering of the vehicle or power steering fluid in reservoir is below operating level, or if there is an obvious leak of power steering fluid. Do not reject for dampness.

NOTE: If the vehicle is equipped with power steering, the engine must be running during testing.

11. Power steering hoses have any cracks, crimps, or restrictions or are abraded, exposing inner fabric; tubing or connections leak or are crimped, restricted, cracked, or broken. Power steering tubing and hoses must be secured against chaffing, kinking, or other mechanical damage and be installed in a manner that prevents contact with the vehicle's exhaust system or any other source of high temperatures.
12. Power steering belt does not have sufficient tension, is frayed, or missing. The serpentine belt should only be rejected if a chunk of the ribbing is missing or a deep cut or crack exposes the inner fabric of the belt. (Do not reject for the many little surface cracks that appear in the ribs or back.)
13. Any modification has been made to any part of the steering or suspension system that affects proper steering or suspension or any part of the original suspension system has been disconnected.

NOTE: "All thread rod material" shall not be used as U-bolts in the suspension system.

Vehicles registered as street rods may substitute any part of the original suspension system provided the components are installed in accordance with the component manufacturers' specifications.

14. Any modification or replacement has been made to the steering wheel that affects proper steering. The steering wheel shall be rejected if the outside diameter is less than 13 inches unless original factory equipment.
15. Steering column has any absence or looseness of bolts or positioning parts, resulting in motion of the steering column from its normal position.
16. A spring is broken, sagging or misaligned, shackles are worn or loose, or if air bags are collapsed or the air suspension system leaks or is deflated.

CAUTION: Underneath inspection of a vehicle equipped with air suspension with excessive leak down could result in serious personal injury.

17. Shock absorbers or cross stabilizer links are disconnected, broken, bent, loose, or do not function properly on vehicles with this design.
18. Any front or rear axle or suspension positioning parts are cracked, broken, loose, worn, bent or missing, resulting in shifting of an axle from the normal position. Any control arm or suspension positioning part using bushings for control, support and normal functioning is missing the bushing, or the bushing is worn to the extent that the component can be moved by hand along the axis of the component.

NOTE: All rear suspension parts including but not limited to control arms (upper and lower ball joints, radius or torque arms, stabilizer bars, and trailing arms) shall not have any damage or noticeable play when checked with hand pressure.

19. A MacPherson strut installed on a motor vehicle is broken, bent, loose or does not function properly.

NOTE: Do not reject a shock absorber or MacPherson strut unless there is evidence of leakage that causes the device not to function properly.

20. If vehicles measured movement at top or bottom of tire is greater than:

Wheel Size:	less than 17 inches -	1/4 inch
	17 to 18 inches -	3/8 inch
	over 18 inches -	1/2 inch

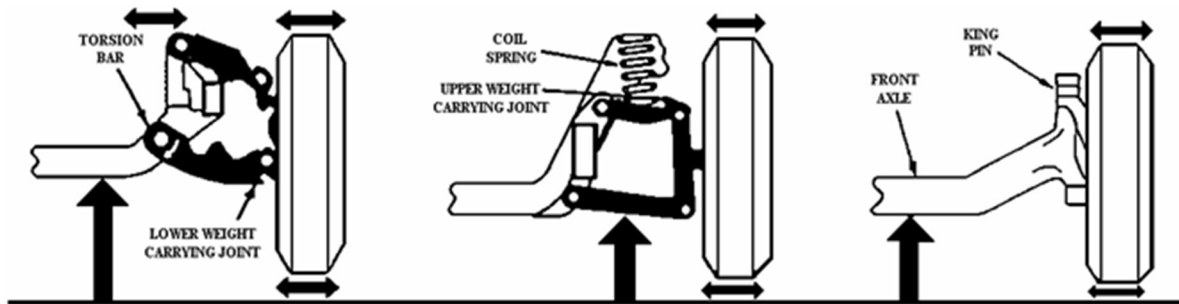

Proper lifting for wheel bearing, steering linkage looseness, and king pin play action

FIGURE A

FIGURE B

FIGURE C

NOTE: King pin play. If vehicle is equipped with king pins, first eliminate all wheel bearing movement by applying service brake. With front end lifted as illustrated for inspecting wheel bearings (Figure C), grasp the tire at the top and bottom and attempt to move it in and out to detect looseness. Measure the movement at the top or bottom of the tire at the outer circumference.

C. Wheel bearing/steering linkage.

Reject vehicle if any wheel bearing is excessively worn or not properly adjusted; any cotter key or other locking device is missing or inoperative.

NOTE: Lifting techniques vary for measuring wheel bearing movement. On vehicles with coil spring or torsion bar on lower support arm - hoist at frame (Figure A). On vehicles with coil spring on upper support arm - hoist at lower support arm (Figure B). On front wheel drive vehicles, the inspector must consult manufacturer's lifting information.

NOTE: With vehicle lifted properly, grasp tire at top and bottom, rock in and out and record movement. Wheel bearing looseness is detected by the relative movement between the brake drum or disc and the braking plate or splash shield.

CAUTION: If air suspension vehicles are hoisted via body support area, air spring damage may occur if the air suspension switch is not turned off. Reject vehicle if relative movement between drum and backing plate (disc and splash shield) is more than 1/8 inch measured at the outer circumference of the tire.

D. Steering linkage play.

1. Reject vehicle if measured movement at front or rear of tire is greater than:

Wheel Size:	16 inches or less -	1/4 inch (6.5mm)
	17 to 18 inches -	3/8 inch (9.5mm)
	over 18 inches -	1/2 inch (13mm)

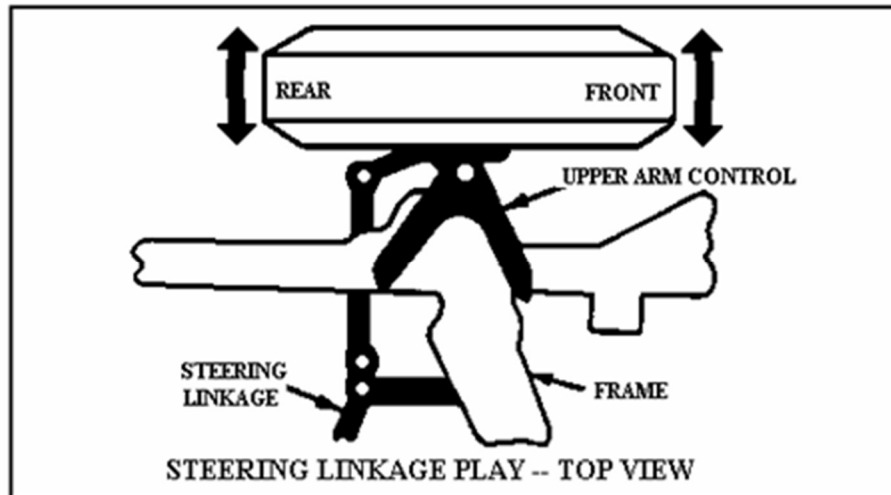

NOTE: First eliminate all wheel-bearing movement by applying service brake. With vehicle lifted as shown in the diagram and wheels in straight-ahead position, grasp front and rear of tire and attempt to move assembly right and left without moving the steering gear.

2. Reject vehicle if the steering mechanism is unusually tight or binding when turning the steering wheel completely to the left or right or the steering mechanism will not turn in both directions stop to stop.
3. Reject vehicle if the steering stops have been removed or adjusted in so that steering radius is reduced.

E. Steering lash/travel.

Reject vehicle if inspection reveals excessive wear or looseness in any ball stud, end assembly, pivot point, mechanical linkage or if steering gear box has any loose or missing bolts, or excessive wear, or looseness is found at any other location in the steering that adversely affects the steering of the vehicle.

NOTE: For vehicles equipped with power steering, the engine must be running and the fluid level, belt tension and belt condition must be adequate before testing.

With road wheels in straight ahead position, turn steering wheel until motion can be detected at the front road wheels. Align a reference mark on the steering wheel with a mark on a ruler and slowly turn steering wheel in the opposite direction until motion can again be detected at the front road wheel (see diagram). Measure lash at steering wheel. Special lash-checking instruments may be used to measure free play in inches or degrees.

Such instruments should always be mounted and used according to the manufacturer's instructions. Reject vehicle if steering wheel movement exceeds:

Power - 2 inches

Manual - 3 inches

Rack & Pinion - (Power or Manual) - 0.4 inch - see note

NOTE: No play is permissible for Volkswagen and Audi vehicles - consult respective manufacturer's specifications.

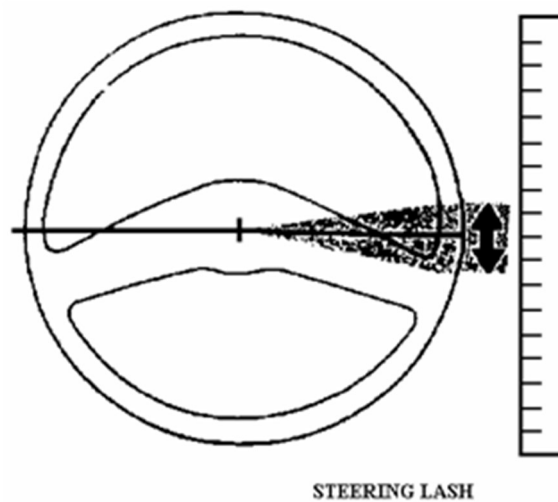

F. Steering lash/travel; trucks.

NOTE: Before inspection, the vehicle must be placed on a smooth, dry, level surface. For vehicles equipped with power steering, the engine must be running and the fluid level, belt tension and belt condition must be adequate before testing. With road wheels in straight ahead position, turn steering wheel until motion can be detected at the front road wheels. Align a reference mark on steering wheel with a mark on a ruler and slowly turn steering wheel in the opposite direction until motion can be detected at the front road wheel. Measure lash at steering wheel. Special lash-checking instruments are also available, measuring free play in inches or degrees. Such instruments should always be mounted and used according to the manufacturer's instructions. With vehicle raised, visually inspect steering linkage, ball studs, tie rod end socket assemblies and all pivot points.

NOTE: On vehicles with power steering, engine must be running.

Reject vehicle if steering wheel movement exceeds:

Steering Wheel Size and Lash

Steering wheel diameter	Manual steering system	Power steering system
16 inches or less	2 inches (51 mm)	4-1/4 inches (108 mm)
18 inches	2-1/4 inches (57 mm)	4-3/4 inches (121 mm)
19 inches	2-3/8 inches (60 mm)	5 inches (127 mm)
20 inches	2-1/2 inches (64 mm)	5-1/4 inches (133 mm)
21 inches	2-5/8 inches (67 mm)	5-1/2 inches (140 mm)
22 inches	2-3/4 inches (70 mm)	5-3/4 inches (146 mm)

G. Ball joint wear (front and rear). There is a trend among U.S. automobile manufacturers toward the use of "wear-indicating" ball joints. Many vehicles on the road, however, do not have wear-indicating ball joints. The inspection of both types will be discussed. With the broadening use of rear suspension ball joints, their inspection shall be made in accordance with manufacturer's recommended procedures. Figures 1, 2, 3 and 4 illustrate the proper hoisting for checking most ball joints. On late model vehicles, it may be necessary to check for both horizontal and vertical movement. Figures 1, 2, 3 and 4 illustrate the proper hoisting for checking ball joints.

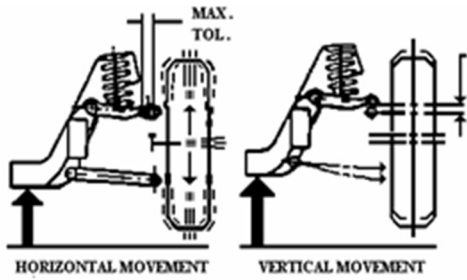

SPRING ON UPPER CONTROL ARM

FIGURE 1

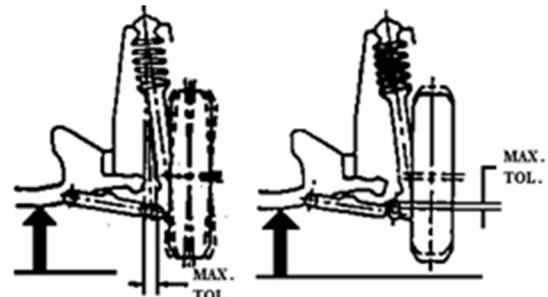

MACPHERSON STRUT

FIGURE 2



FIGURE 3

SPRING OR TORSION BAR ON LOWER CONTROL ARM
RAISING POSITIONS FOR SUSPENSION SYSTEMS

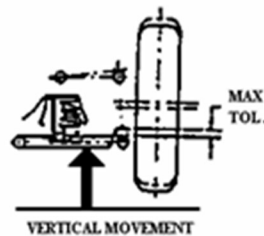

FIGURE 4

NOTE: To check ball joint wear on vehicles when the spring is supported on the upper control arm or when the spring is a part of a MacPherson strut or wear in any other type suspension not using ball joints when the front wheels are suspended on a solid axle, the vehicle must be hoisted as shown in Figure 1 or 2.

NOTE: Upper control arm must be stabilized in normal load carrying position by means of an upper control or other support tool to ensure ball joint is in unloaded position.

NOTE: To check ball joint wear on vehicles not listed in above referred to section and diagram or tables when the spring is supported on the lower control arm; and to check the king pin wear in any other type suspension not previously described when the wheels are independently suspended, the vehicle must be hoisted as shown in Figure 3 or 4.

H. Ball joints without wear indicators (front and rear).

1. If play is detected in any ball joint without "wear-indicating" ball joints, it will be necessary for the inspection to be made in accordance with the manufacturer's recommended procedures and specifications prior to rejecting the vehicle.
 2. If there are no manufacturer's recommended procedures and specifications, the lower ball joints will be checked when hoisted as in Figure 1 or 2 of subsection G of this section, or in the upper ball joints when hoisted as in Figure 3 or 4 of subsection G of this section. There should be no noticeable play detected in the ball joints when checked in this manner.
 3. Reject vehicle if play exceeds the manufacturer's specifications. Inspectors shall use a dial indicator or ball joint checking gauge when checking for play of a ball joint, when procedures and specifications are provided by the manufacturer.
- I. Ball joints with wear indicators. Support vehicle with ball joints loaded (in normal driving attitude). Wipe grease fitting and checking surface free of dirt and grease. Determine if checking surface extends beyond the surface of the ball joint cover.

Reject vehicle if checking surface is flush with or inside the cover surface.

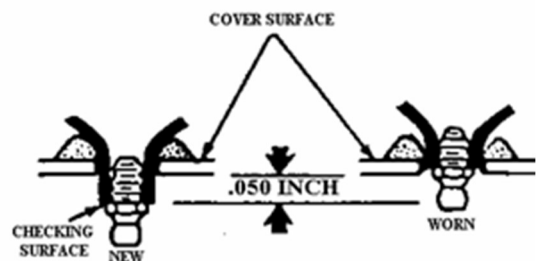
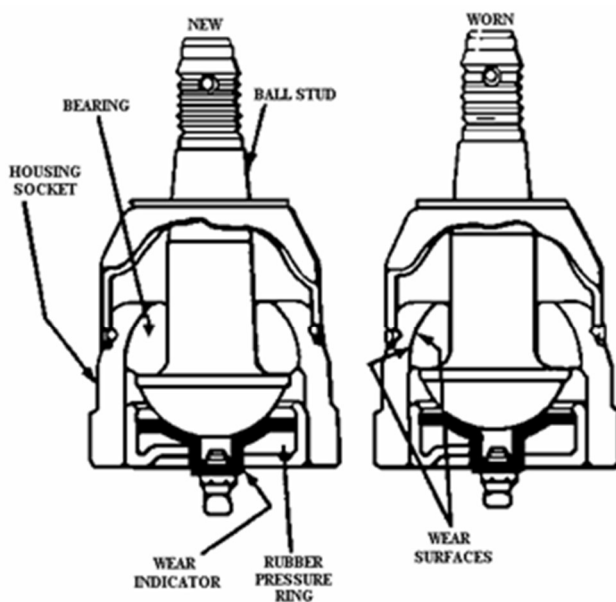

BALL JOINT WEAR INDICATOR

Wear is indicated by the protrusion of the 1/2" diameter boss, (exaggerated for illustration) into which the grease fitting is threaded for greasable ball joints. This same boss exists and should be used to indicate wear in non-greasable ball joints. This round base projects .050" beyond the surface of the ball joint cover on a new, unworn joint.

To inspect for wear, support vehicle by wheels so that the lower ball joints are in a loaded condition. Wipe the grease fitting or boss free of dirt and grease. Observe or scrape a scale, screwdriver or fingernail across the cover. If the grease fitting boss is flush or inside the cover surface, reject vehicle.

- J. American Motors Pacer (only). Position vehicle on level surface. Remove lubrication plug from lower ball joint. Check lower ball joint clearance by inserting stiff wire or thin rod into lubrication plug hole until it contacts ball stud. Accurately mark rod with knife or scribe where it aligned with outer edge of plug hole. Distance from ball stud to outer edge of plug hole is ball joint clearance. Measure distance from mark to end of rod. (Anything less than 7/16 inch is acceptable.)

Reject vehicle if distance measured is 7/16 inch or more.

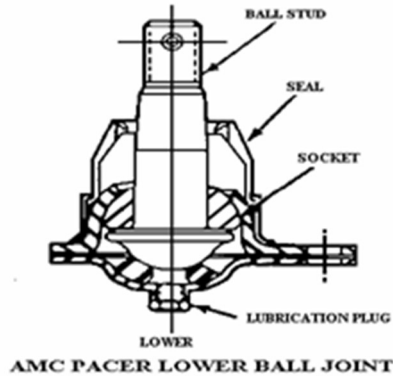

- K. Chrysler front-wheel drive vehicles (lower only). With the weight of the vehicle resting on the road wheels, grasp the grease fitting as shown below and attempt to move fitting. No mechanical assistance or added force is necessary.

Reject vehicle if grease fitting shows any movement.

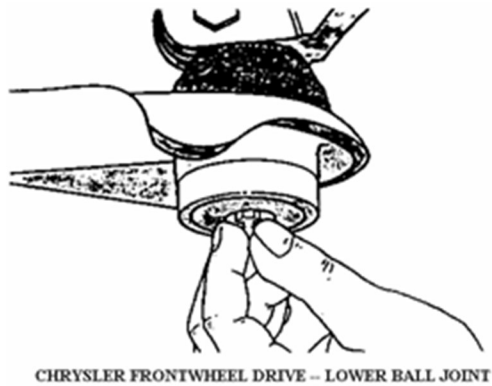

19VAC30-70-120. Frame, engine mounts, coupling devices and emergency chains.

Inspect for and reject if:

1. Frame or unitized (monocoque) body of any motor vehicle, trailer or semitrailer possesses one or more of the following defective characteristics: rust holes; any area of the frame or its components is broken, cracked, sagging, or bent; or damaged at any location to include any welded joint; the frame is corroded to the point where it is weakened; or any holes are drilled in the top or bottom rail flanges of the frame or the frame or cross-member (except as specified by the manufacturer).

NOTE: Any welded repair of the frame must be in accordance with the vehicle manufacturer's recommendations.

NOTE: All sections of a unitized frame are considered stress-bearing to include pinch and side rails, floors, and all support framework.

2. Engine or transmission mounts and hardware is broken or missing. This includes all hardware bolts and bushings used for mounting to the vehicle's frame, engine, or transmission. Any engine or transmission mount shall be rejected if they allow the power train to come in contact with the firewall or other body parts. Anybody, truck bed, or bumper mounts or mounting hardware shall be rejected if they do not properly secure these components to the frame as originally designed.
3. Trailer hitch or pintle hook is not securely attached. Reject if the pintle eye or trailer drawbar has any cracks or if any welding repairs have been made to the pintle eye.
4. Chains, cables, etc., used to attach a towed vehicle are not securely attached or are broken, worn or abraded.
5. Fifth wheel does not lock in position or have a locking mechanism in proper working order.
6. Fifth wheel assembly system has any leak of fluid or air.
7. Fifth wheel has any broken, missing, or damaged parts; or is not securely attached to the frame.
8. Trailer king pin is not secure, or is broken or worn so as to prevent secure fit in fifth wheel.
9. Any movement is detected at any location where any device has been placed between the body and the chassis.
10. Trailer is not equipped with an emergency chain or steel cable.

NOTE: Fifth wheel assembly system does not require an emergency chain or cable. A fifth wheel is defined as a device which interfaces with and couples to the upper coupler assembly of a semitrailer. The upper coupler assembly is a structure consisting of an upper coupler plate, king pin and supporting framework which interfaces with and couples to a fifth wheel. Ball and socket connections also referred to as hitch and coupling connections are not fifth wheel assemblies and do require an emergency chain or steel cable.

19VAC30-70-130. Tires; wheels; rims.

Inspect for and reject if:

1. Any tire is marked specifically for use other than on the highway such as “For Farm Use Only,” “For Off-Highway Use Only,” “For Mobile Home Use Only,” or “For Trailer Use Only.”

EXCEPTION: “For Trailer Use Only” tires are allowed when installed on trailers only.

2. A radial tire is mismatched on the same axle with a bias ply tire or a bias belted tire.
3. Bias ply or bias belted tires are used on the rear axle when radial ply tires are used on the front axle.

EXCEPTION: On a two-axle vehicle equipped with truck tires with 20-inch rim diameter and larger, bias or radial tires may be used on either axle if the vehicle has dual rear wheels or is equipped with wide-base single tires.

4. A vehicle has installed on any axle a space saver emergency spare tire that is intended for temporary use.
5. Any motor vehicle, trailer or semitrailer, except the dual wheels installed on motor vehicles having seats for more than seven passengers (i) operated wholly within a municipality or (ii) operated by urban and suburban bus lines, which are defined as bus lines operating over regularly scheduled routes and the majority of whose passengers use the buses for traveling a distance not exceeding 40 miles, measured one way, on the same day between their place of abode and their place of work, shopping areas, or schools, is equipped with a tire that has a tread depth measuring less than $2/32$ of an inch when measured as follows:

NOTE: The exemptions provided in (i) and (ii) of this subdivision 5 do not apply to buses owned or operated by any public school district, private school or contract operator of buses.

NOTE: Measure in two adjacent tread grooves where tread is thinnest. Refer to Figure 1. If either of the grooves measure $2/32$ of an inch or more, no further measurements are necessary and tread depth is satisfactory. Do not take measurements from the tread wear indicators.

6. If both adjacent grooves measure less than $2/32$ of an inch, the tire tread depth must be measured again at two additional equally spaced intervals around the circumference of the tire in a like manner as the first measurement.

Refer to Figure 1. If the tread depth is less than $2/32$ of an inch in two adjacent tread grooves at each of the equally spaced intervals, the tire must be rejected.

MEASURE WHERE THE TREAD IS
THINNEST IN TWO ADJACENT
TREAD GROOVES

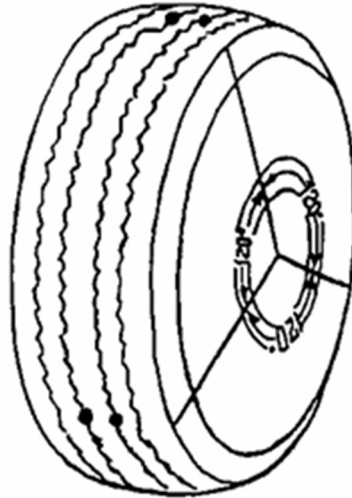

FIGURE 1

IF THE DEPTH IS LESS THAN 2/32-
INCH IN BOTH GROOVES,
MEASURE AT TWO ADDITIONAL
EQUALLY SPACED INTERVALS

7. A tire equipped with tread wear indicators if found to have such indicators in contact with the pavement in any two adjacent grooves at three equally spaced intervals around the circumference of the tire. Refer to Figure 2.

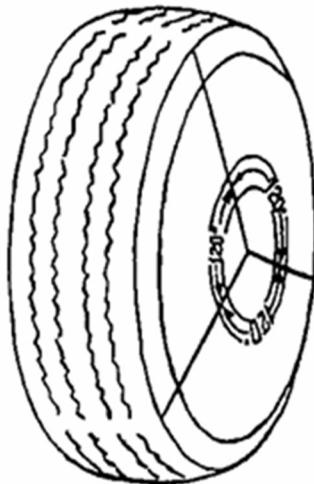

FIGURE 2

REJECT IF THE TREAD WEAR INDICATORS ARE IN
CONTACT WITH THE PAVEMENT IN ANY TWO ADJACENT
GROOVES AT THREE EQUALLY SPACED LOCATIONS

8. Any tire has a cut or puncture into the fabric. This does not include a plug or patch that may be used as a manner of repair.

NOTE: Plugs or patches shall be in the tread area only. Plugs or patches are not permitted in the sidewall of the tire.

9. Any tire is worn so that the fabric or steel cord is visible.
10. Any tire has knots or bulges in its sidewalls or if there is evidence of a broken belt under the tread, or if the tread is separating from the fabric. Any cracks in the sidewall where separation in the rubber is detected or the fabric is exposed, not to include fine hairline cracks.
11. Any tire that has been recut or regrooved except commercial tires so designed and constructed to provide for acceptable and safe recutting and regrooving. (Regrooved tires must be identified on each sidewall as a regrooved tire.)
12. Any wheel studs, bolts, nuts, lugs, or other fasteners (both spoke and disc wheels) are loose, broken, cracked, stripped, missing, damaged, or otherwise ineffective.
13. Wheels are installed on the vehicle in a reversed position, except the wheels on vehicles that are reversed to perform part of a dual wheel combination.
14. Directional tires or wheels designed and manufactured to travel in one direction of rotation are not properly installed.
15. Rims or wheels are bent, cracked, or damaged so as to affect safe operation of the vehicle. Reject if lug nut holes are elongated (out of round).

NOTE: Refer to subdivision 1 of 19VAC30-70-180 (Clearance lamps and reflectors) for tires that exceed more than four inches from the body.

19VAC30-70-140. Headlamps; except motorcycles.

A. Inspect for and reject if:

1. Any motor vehicle is not equipped with at least two headlamps of an approved type. An approved headlamp assembly that contains bulbs for both the high and low beams within the same housing shall be considered one headlamp. The headlamps must be marked with the headlamp manufacturer's name or trademark, and DOT. If the headlamp bulbs are replaceable, the headlamp lens must be marked with the headlamp light source type (bulb) for which it was designed and the bulb must match the lens code.

NOTE: If the headlamp system is stamped to accept halogen bulbs, then the replacement bulbs must be halogen as well. Retrofitting an HID or LED bulb to a halogen headlamp system does not conform to the standards set forth by the Federal Motor Vehicle Safety Standards (FMVSS) and shall be rejected.

If the entire headlamp assembly is changed from a halogen system to an LED system and does not require the manufacturer's original wiring to be cut or compromised, then it shall be considered for inspection if it meets the requirements of subdivision A 2 of this section.

2. Headlights are not of the same approved type (Halogen, HID, LED, etc.) except for sealed beam headlamps, or the replacement headlamp system does not contain all properly marked DOT and SAE stamps certifying that it has met and complied with the standards set forth by the Federal Motor Vehicle Safety Standard (FMVSS) 108.

NOTE: Replacement headlamps stamped with a DOT or SAE approval marked with the headlamp manufacturer's name or trademark shall be considered approved by the Superintendent of State Police and will not be required to be listed on the Virginia Motor Vehicle Approved Equipment List.

3. In any headlamp the lens is cracked, broken, discolored, or rotated away from the proper position, or the reflector is not clean and bright.
4. Moisture or water buildup in headlamp is such that it affects the aiming pattern.
5. Headlamps omit light other than white. Light tints of color may be acceptable if the headlamp and headlamp bulbs are marked as required.
6. Bulbs are not of an approved type and marked with all of the following: light source type, the manufacturer's name or trade mark, and DOT.

NOTE:

Approved headlamp bulbs: HB1, HB2, HB3, HB3A, HB4, HB4A, HB5, H1, H3, H7, H8, H8B, H9, H9B, H9C, H11, H11B, H11C, H13, H13C, H15, HIR1, HIR2, H18, H19.

Approved headlamp bulbs that require ballast: 9500, D1R, D1S, D2R, D2S, D3R, D3S, D4R, D4S, D5S, D7S, D8S, D9S.

Approved headlamp ballasts must be marked with the light source type (bulb) and DOT. The bulb type marked on the ballast must match the marking on the headlamp lens.

7. Any filament or bulb in headlamps fails to burn properly or headlamps are not at the same location or configuration as designed by manufacturer. (Location and type of headlamps can be found in subsection E of this section.)
8. Wiring is dangling or connections are loose, or if proper filaments do not burn at different switch positions; or if switches, including foot or hand dimmer, do not function properly and are not convenient to the driver.
9. Foreign material is placed on or in front of the headlamp lens or interferes with the beam from the lamp. No glazing may be placed over or in front of the headlamps unless it is a part of an approved headlamp assembly.
 - a. Reject if vehicle has wire, unapproved lens or plastic covers, any other materials that are not original equipment or any colored material placed on or in front of the headlamps.
 - b. Vehicles registered as street rods may have clear, rigid plastic or glass headlamp lens covers in front of sealed beam units to replace original manufacturer's equipment.

EXCEPTION: A clean impact film known as Headlight Savers produced by Grand Prix Motoring Accessories may be applied to the headlight lens to absorb impact of rocks, etc.

10. Lamps can be moved easily by hand due to a broken fender or loose support, or if a good ground is not made by the mounting.
11. Headlamps, auxiliary driving lamps and front fog lamps are not mounted so that the beams are aimable and the mounting does not prevent the aim of the lighting device from being disturbed while the vehicle is operating on public roads. All lamps shall be securely mounted on a rigid part of the vehicle.
12. A headlamp visor is over two inches long unless part of the original body design.
13. The high beam indicator in the driver's compartment does not burn when the high beam is on or does not go off when the low beam is on. (Vehicles not originally equipped with an indicator are not required to comply unless sealed beam headlamps have been installed.)

B. Aiming the headlamps.

1. Inspectors shall rely on their education, training, and experience to determine if the headlamps are properly aimed. If improper alignment is observed, headlamps shall be checked for proper aim by using an optical headlamp aimer, except on vehicles equipped with on-board aimers.

Headlamp aim on vehicles with on-board aimers shall be checked by visually examining the leveling device mounted either on or adjacent to the headlamp. Reject the vehicle if the leveling device shows the headlamp adjustment to exceed indicated specifications.

NOTE: Driving lamp and fog lamps must be visually inspected to ensure proper aiming. If improper alignment is observed, the optical aimer shall be used to correct any misalignment.

2. Headlamps are not aimed within the following tolerances using the optical aimer.

- a. The center of the hot spot of all single element high beam lamps is set more than four inches up or down from the horizontal centerline or more than four inches to the left or right from the vertical centerline.
- b. The left edge of the lamp pattern of any low beam lamp or any combination or multi-element lamp is more than four inches to the left or right of the vertical centerline or the top edge of the lamp pattern is more than four inches above or below the horizontal centerline when checked on low beam.

C. Optical aimer.

- 1. Optical aimers must be properly calibrated and used in the manner recommended by the manufacturer.

The optical headlamp machine must be aligned to the vehicle in accordance with the manufacturer's specifications.

- 2. When aiming headlamps, first look for the type of lamp, which will be found embossed on the lens. The type determines which aiming requirements must be followed for the optical aimer.
- 3. All low beam or combination/multi-element headlamps must be set by aiming the lamp pattern with the lamps set on low beam.

NOTE: If attempting to align a composite or sealed beam lamp with a high and low beam within the same housing, align only the low beam. If aligning a four-lamp system with high and low beams in separate housings, it may be necessary to cover the low beam while aligning the high beam, if all four lamps are on at the same time.

- 4. Pattern should be aimed so that the left edge does not extend to the left or right of straight ahead, and the top of the pattern should be even with the horizontal.

Pattern "A" represents the light pattern as it should appear on the view screen of the approved aimer when checking the low-beam pattern on a single element headlamp or a combination multi-element headlamp.

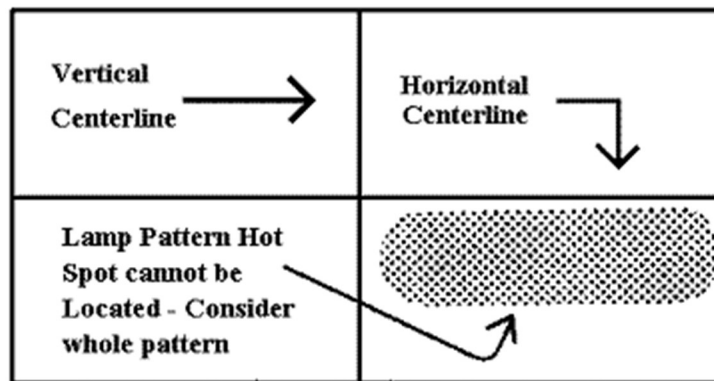

PATTERN A - COMBINATION MULTIELEMENT OR LOW BEAM LAMP

- 5. All VOL and VOR headlamps will be aimed as follows:

To properly aim a combination multi-element or low-beam VOL or VOR headlamp assembly, the headlamp pattern should be aimed on low beam only.

Letters marked on the headlamp cover should properly identify VOL and VOR headlamps.

NOTE: VOL and VOR headlamps will normally have only one adjustment, which will be for the vertical aim only. The horizontal aim should be disregarded, as the horizontal aim is preset at the factory.

6. All single element high beam headlamps shall be set by aiming the center of the hot spot with the lamps set on high beam.
7. Aim straight ahead-center of the hot spot should be centered with the vertical and horizontal centerlines.

Pattern "B" represents the light pattern as it should appear on the view screen of the approved aimers.

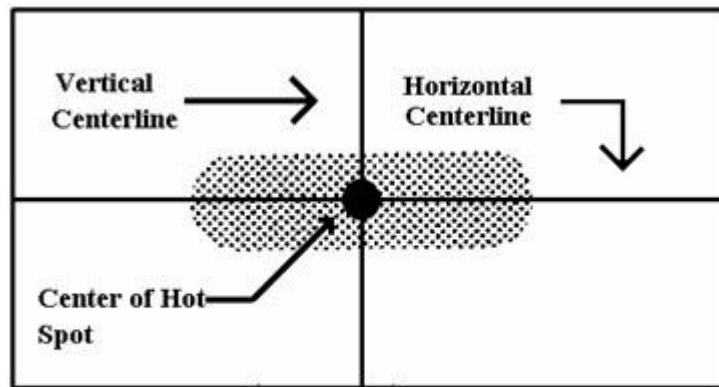

PATTERN B - SINGLE ELEMENT HIGH BEAM LAMP

8. When lamp pairs are mounted horizontally, the low beam lamp must be on the outer side and when mounted vertically, the low beam lamp must be at the higher position in the pair.
9. The four headlamp system must be wired so that only the lower beam lamp will burn when the light beams are depressed. When switched to high beams, both high beam and low beam may burn.

The "F" type halogen headlamp 1986 (LF-UF) of the four headlamp system will function in the following manner: system must be used so the low beam does not burn with the high beam.

D. Headlamps on vehicles used for snow removal. Approved auxiliary headlamps may be mounted above the conventional headlamps. (These lamps must be in compliance with this section in its entirety, subdivision 7 of 19VAC30-70-150, and 19VAC30-70-170.)

E. Inspect for and reject if:

1. Lamps are not an approved type as previously indicated in subdivision A 6 of this section.
2. Lamps are not mounted in a manner that will permit proper aiming.
3. Lamps are mounted so as to obstruct the driver's vision.
4. The auxiliary headlamp circuit does not contain a switch that will deactivate the primary headlamp system when the auxiliary headlamps are in use.

5. Auxiliary headlamps are not aimed in accordance with the provisions of subdivision B 2 of this section.
6. Headlamps are not wired in accordance with the provisions of subdivision C 8 of this section.

NOTE: Light patterns shown in the following diagram will be displayed on the most recently approved light machines produced by Hopkins and Symtech Corporations.

HEADLAMP PATTERNS

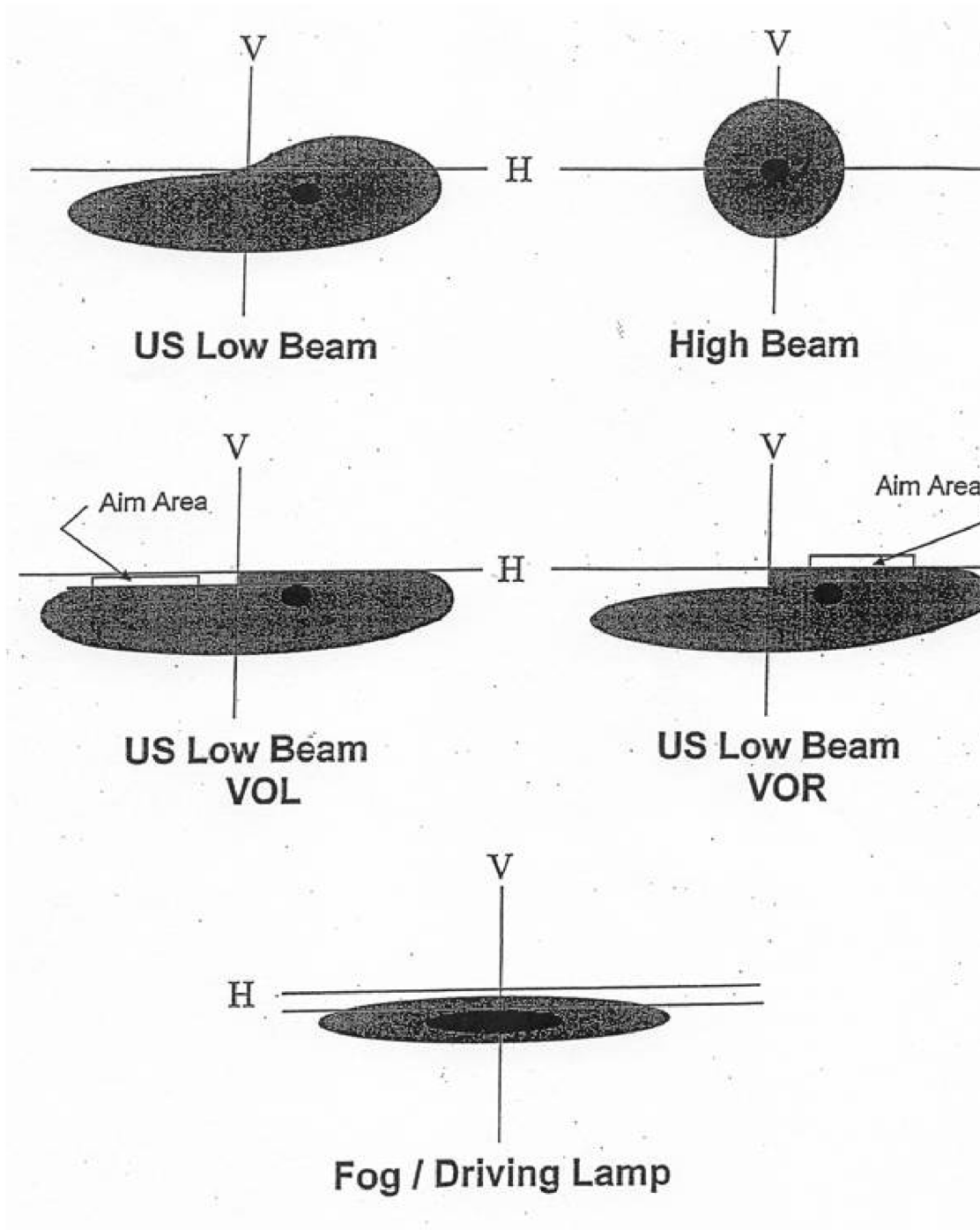

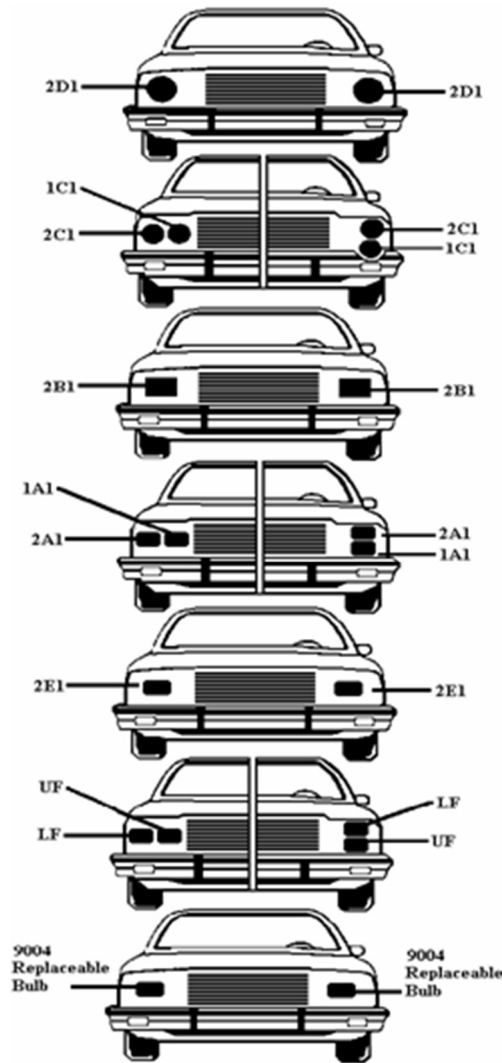

Locations of Type 1, Type2, LF/UF, and Replaceable Bulb Headlamps

NOTE: Always inspect the following sealed beam and replaceable bulb and integral beam headlamps on LOW BEAM only:

- 5-3/4 inch, marked 2, 2C, or 2C1
- 7 inch, marked 2, 2D, or 2D1
- 100 X 165mm rectangular, marked 2A, 2A1, or 2E1, 2G1 or 2H1
- 200 X 142mm rectangular, marked 2B or 2B1
- Replaceable bulb headlamp, marked LF with 9004 (HB1)
- 92 X 160mm rectangular, marked LF
- Replaceable bulb headlamps with 9006 (HB4) alone or in combination with 9005 (HB3)
- 55 X 135mm rectangular, marked L
- Integral beam headlamp when high and low beam reflectors move together.

19VAC30-70-150. Rear lamps: tail lamp; and rear lamp combinations.

Inspect for and reject if:

1. Vehicle is not equipped with a rear (tail lamp) or rear lamp combination of an approved type or light assembly does not work as designed by the manufacturer.
2. The vehicle is equipped with more than one rear lamp, if all are not in operating condition.
3. Lens on rear lamps, or lens area in combination rear lamps (tail lamps) are not red. LED (light-emitting diode) lights with a clear lens are acceptable. Vehicles equipped with multiple LED lights (not filament-burning bulbs) will pass a safety inspection if more than 50% of the diode lights are burning.

NOTE: Replacement tail lamps, commonly sold as “clear” tail lamps or “Euro-Tail” lamps will not pass inspection if the red lamps are replaced with clear ones.

4. Lens has piece broken from it or does not fit properly. The lens may have one or more cracks provided an off-color light does not project through the crack or cracks. Taping or gluing cracks or pieces is not permitted.
5. Filament in all rear (tail) lamps does not burn when headlamp switch is turned on to any position, or if lamps do not provide a red light visible to the rear through an approved red lens as annotated in subdivision 1 of this section. If it is a rear lamp combination incorporated with a wraparound side-marker light, then the side-marker lens must be red and not a clear lens with a red bulb. If the bulb, socket and wiring are removed from the side-marker lamps, then they will not be considered during the inspection.
6. Rear (tail) lamp is not mounted near extreme rear of vehicle. Dump trucks and other specially constructed vehicles may mount the rear lamp at a point other than on the extreme rear, provided such rear lamp is clearly visible from the rear, and further provided that a red reflector of an approved type is mounted on the extreme rear. In unusual cases, the rear lamp may be mounted on the cab. Reject if the lamp is hidden by a bolster or other part of the body or frame, is not mounted securely, or if the lamp does not make a good electrical contact.
7. The vehicle has wire, unapproved lens or plastic covers, any other materials that are not original equipment or any colored material placed on or in front of rear lamps, and rear lamp combinations.
8. Wiring or electrical connections are defective or filaments do not burn.

NOTE: Every trailer shall carry at the rear two red tail lights of a type approved by the superintendent.

19VAC30-70-160. Auxiliary lamps: backup; cornering; driving; fog; spot and warning.

- A. Auxiliary lamps on a vehicle consist of seven general types: backup lamps (SAE-R), cornering lamps (SAE-K), driving lamps (SAE-Y), front fog lamps with an amber or clear lens (SAE-F) and rear fog lamps with red lens (SAE-F2), spot lamps (SAE-O), warning lamps (SAE-W, W2, W3), and daytime running lamps (DRLs) (SAE-Y2).

NOTE: Any light or lighting device not defined or otherwise authorized in 19VAC30-70-140 through 19VAC30-70-200 that is installed on a vehicle shall not be considered for inspection as long as it remains unlit during the inspection and is not wired to activate with any required lighting system in this Chapter.

- B. School buses may be equipped with an eight-lamp warning system of two red and two amber warning lamps of an approved type (SAE-W2) on the front and rear of such vehicle.

1. School buses may also be equipped with roof-mounted flashing white or amber warning lamps of an approved type (SAE-W2).
2. In addition to required warning lamps, school buses may be equipped with a stop signal arm consisting of an octagonal sign which meets FMVSS specifications (Federal Motor Vehicle Safety Standards, 49 CFR Part 571). The stop signal arm shall be reflectorized or be equipped with two red warning lamps of an approved type.

- C. No more than four lamps, including two headlamps, may be lighted at any time to provide general illumination ahead of the vehicle. An approved headlamp assembly that contains bulbs for both high and low beams within the same housing shall be considered one headlamp.

- D. Inspectors shall rely on Article 3 (§ 46.2-1010 et seq.) of Chapter 10 of Title 46.2 of the Code of Virginia to determine if a vehicle should be allowed to have such lighting (such as emergency vehicles, dealer demo vehicles, etc.).

- E. Inspect for and reject if:

1. Auxiliary lamp is being used for a purpose other than for which it is manufactured or previously approved by the superintendent as defined in subsection A of this section.

EXCEPTIONS: An auxiliary lighting device that is both covered and unlit shall not be considered for inspection.

2. A vehicle has installed on it a warning lamp (SAE-W) that is not of an approved type or has been altered.
3. Vehicle has wire, unapproved lens or plastic covers, or any other materials that are not original equipment or any colored material placed on or in front of any auxiliary lamps: backup, cornering, daytime running, driving, fog, spot or warning lamps.

4. Motor vehicles may be equipped with more than two fog or auxiliary lights; however, only two of these types of lights can be illuminated at any time. Reject a vehicle equipped with a headlamp mounted or used as an auxiliary lamp.
5. Vehicle is equipped with an auxiliary lamp that does not function properly. (If an auxiliary lamp has been modified by removing the wiring, bulb and socket, the unit will be considered an ornament and not a lamp and will not be considered in inspection.)
6. Vehicle is equipped with a lighted advertising sign, except commercial motor vehicles, buses operated as public carriers, taxicabs, and privately-owned passenger cars used for home delivery of commercially prepared food. Commercial motor vehicles, buses operated as public carriers, and taxicabs may be equipped with vacant and destination signs and one steady burning white light for the nighttime illumination of external advertising. Privately-owned passenger cars used for home delivery of commercially prepared food may be equipped with one steady burning white light for the nighttime illumination of a sign identifying the business delivering the food. Do not reject approved identification lights.
7. The lens has a piece broken from it. The lens may have one or more cracks provided an off-color light does not project through the crack. Taping or gluing cracks or pieces is not permitted.
8. Backup lamps are not required. However, if installed they must operate and be inspected.

Inspect for and reject if:

- a. Required lamps are not of an approved type (SAE-R) or a lamp has been altered;
 - b. Wiring or electrical connections are defective or filaments do not burn;
 - c. The lens has a piece broken from it. The lens may have one or more cracks provided an off-color light does not project through the crack. Taping or gluing cracks or pieces is not permitted;
 - d. Lens is other than clear. LED (light-emitting diode) lights with a clear lens are acceptable if of an approved type. For those vehicles that are equipped with a multiple LED light (not filament-burning bulbs), they will pass inspection if more than 50% of the diode lights are burning;
 - e. Lamps are not wired into the reverse gear. Vehicles manufactured without backup lamps may be wired into an independent circuit.
 - f. Any backup lamp(s) that do not emit white light.
9. Cornering lamps are not required. However, if installed they must operate and be inspected.

Inspect for and reject if:

- a. Required lamps are not of an approved type (SAE-K) or a lamp has been altered;
- b. Wiring or electrical connections are defective or filaments do not burn;

- c. The lens has a piece broken from it. The lens may have one or more cracks provided an off-color light does not project through the crack. Taping or gluing cracks or pieces is not permitted;
 - d. The color of the light and lens is other than clear or amber;
 - e. The lamps do not burn in conjunction with the turn signals.
10. Driving lamps are not required. However, if installed they must operate and be inspected.

Inspect for and reject if:

- a. Driving lamps are installed on vehicles equipped with the four-headlamp system, except the "F" type headlamp system;
- b. Driving lamps are not of an approved type or have been altered;
- c. The color of the lamp is other than white or the lens is not clear;
- d. The lens has a piece broken from it or is rotated away from its proper position. The lens may have one or more cracks provided an off-color light does not project through the crack. Taping or gluing cracks or pieces is not permitted;
- e. Wiring or electrical connections are defective;
- f. Any driving lamp is mounted above the level of the regular headlamps, or is not mounted firmly to prevent excessive vibration;
- g. Driving lamps are not wired so that they will burn only when the high beams of the regular headlamps are activated;
- h. Driving lamps are not aimed so that the center of the hot spot drops three inches in 25 feet so that the hot spot is directly ahead of the lamp.

NOTE: Driving lamps must be aimed using the optical headlight aimer. A tolerance of four inches in 25 feet is allowed in both the horizontal and the vertical adjustment.

11. Fog lamps are not required. However, if installed they must operate and be inspected.

Inspect for and reject if:

- a. A vehicle may be equipped with more than two fog lamps; however, not more than two fog lamps can be illuminated at any time;
- b. The lens and light is other than clear or amber. Fog lamps may have black-end bulbs or small metal caps over the end of the bulb;
- c. The lens has a piece broken from it or is rotated away from its proper position. The lens may have one or more cracks provided an off-color light does not project through the crack. Taping or gluing cracks or pieces is not permitted;
- d. Wiring or electrical connections are defective or filaments do not burn;
- e. Any fog lamp is mounted above the level of the regular headlamps, or is not mounted firmly;
- f. Lamps are not wired and aimed according to the following instructions:

- 1) Fog lamps are general illumination lamps as covered in subsection A of this section. They must burn through the tail light circuit even if on a separate switch. If installed on a vehicle with a four-headlamp system, or a vehicle equipped with driving lamps, they must be wired into the low beam circuit.
- 2) Fog lamps must be aimed so that the top edge of the high intensity zone is set at the horizontal centerline and the left edge of the high intensity zone is set at the vertical centerline. (Same as low beam headlights.)

NOTE: Fog lamps must be aimed using the optical headlight aimer. A tolerance of four inches in 25 feet is allowed in both the horizontal and the vertical adjustment.

12. Spot lamps are not required; however, if installed they must operate and be inspected.

Inspect for and reject if:

- a. Vehicle is equipped with more than two spot lamps;
- b. Lamps are not of an approved type (SAE-O) or a lamp has been altered;
- c. The lens in any spot lamp is other than clear or light is not white;
- d. The lens has a piece broken from it or is rotated away from its proper position. The lens may have one or more cracks provided an off-color light does not project through the crack. Taping or gluing cracks or pieces is not permitted;
- e. Wiring or electrical connections are defective or filaments do not burn.

13. Daytime running lamps (DRLs) are not required. However, if installed they must operate and be inspected. DRLs must be installed in pairs.

NOTE: DRLs may or may not be wired into the tail light circuit.

Inspect for and reject if:

- a. Any lamp, except headlamps, used as DRLs if not an approved type (SAE-Y2) and is not marked "DRL";
- b. Fog lamps or parking lamps are used as DRLs;
- c. More than one pair of lamps is used and designated as DRLs;
- d. A DRL is mounted higher than 34 inches measured to the center of the lamp;
- e. The color is other than white to amber;

NOTE: Any DRL optically combined with a turn signal or hazard lamp must deactivate when the turn signal or hazard lamp is activated and then reactivate when the turn signal or hazard lamp deactivates.

19VAC30-70-170. Parking lamps.

A. Parking lamps are not required; however, if installed they must operate and be inspected. Parking lamps may burn in conjunction with the headlamps.

B. Inspect for and reject if:

1. Lamps are not of an approved type (DOT or SAE-P) or a lamp has been altered.

NOTE: The clear lens lights between the headlamps and the red lens lights between tail lamps on various vehicles are approved parking lamps and must work if not rendered inoperative by removing the bulb, socket and wiring from each individual lamp.

2. Parking lamps have other than white or amber lenses showing to the front. If the lens is clear, then the bulb shall be amber.
3. Parking lamps do not burn with the rear lamps.
4. If lens has a piece broken from it. Lens may have one or more cracks provided no off-color light projects through the crack or cracks. Taping or gluing cracks or pieces is not permitted.
5. Reject if the vehicle has unapproved lens or plastic covers, any other materials which are not original equipment or any colored material placed on or in front of the parking lamps.
6. Wiring or electrical connections are defective or filaments do not burn.
7. LED (light-emitting diode) lights with a clear lens are acceptable if of an approved type. For those vehicles that are equipped with a multiple LED light (not filament-burning bulbs), they will pass inspection if more than 50% of the diode lights are burning.

19VAC30-70-180. Clearance lamps, side marker lamps, and reflectors.

Inspect for and reject if:

1. Any motor vehicle, trailer, semitrailer or other vehicle is not equipped with clearance lamps if the vehicle is over seven feet wide or if any portion extends four inches or more outside the front fender line.

NOTE: See 19VAC30-70-550 for vehicles exceeding 10,000 GVWR.

When a motor vehicle with a trailer attached is presented, the combination may be considered as one unit in meeting this requirement. If presented separately, the individual unit must meet these requirements.

2. Lamps or reflectors are not of an approved type or a lamp has been altered; any wires are exposed; unapproved lenses or plastic covers; or any other materials that are not original equipment or any colored material placed on or in front of lamps or reflectors.
3. Lenses or lamps on the front are not amber and lenses on lamps on the rear are not red or if a lens has a piece broken from it. A lens may have one or more cracks provided an off-color light does not project through the crack or cracks. Taping or gluing cracks or pieces is not permitted.

NOTE: For vehicles equipped with a multiple LED (light-emitting diode) light (not filament-burning bulbs): they will pass inspection if more than 50% of the diode lights are burning.

4. Wiring or electrical connections are defective, all filaments do not burn.
5. Two amber lamps are not mounted on the front and two red lamps on the rear, so as to indicate the extreme width of the body, and as high on the permanent body as practical, except that approved 180 degree lamps with yellow or amber lens may be mounted on the side of the vehicle at or as near the front as possible, or if the front is not the widest portion, the lamps may be installed on the side and as near that point as possible. And with the further exception that 180 degree lamps with red lens may be mounted on the side of the vehicle at or as near the rear as possible or if the rear is not the widest portion of the vehicle, the lamps may be installed on the side as near that point as possible.
6. Any vehicle equipped with three red identification lamps with the lamp centers spaced not less than six inches or more than 12 inches apart and installed as close as practicable to the top of the vehicle and as close as practicable to the vertical centerline of the vehicle may have the rear clearance lamps required by subdivision 5 of this section, mounted at any height but indicate as nearly as practicable the extreme width of the vehicle.

NOTE: Other specially constructed vehicles may be equipped with the required clearance lamps not mounted on the extreme rear, provided such red lamps are clearly visible from the rear and provided further that two red reflectors of an approved type are mounted on the extreme rear. In unusual cases the rear lamp may be mounted on the cab and another red reflex reflector placed on the extreme rear.

NOTE: In addition to the required clearance lamps showing to the front and to the rear, a vehicle may be equipped with side marker lamps on the side of the vehicle. When such an installation is used, all of the clearance lamps on the side except the one at or near the rear must have an amber lens. The side marker lamps on the side at or near the rear must have a red lens.

7. Any vehicle covered by subdivision 1 of this section, except school buses, is not equipped with amber reflectors on the sides as near the front as practical, and red reflectors on the rear. The reflectors must be at least 15 inches and not more than 60 inches from the ground. No reflector can have a piece broken from its reflective surface, but may have one or more cracks. Taping or gluing cracks or pieces is not permitted.
8. Any combination of vehicles whose actual length exceeds 35 feet is not equipped with reflex reflectors of a type approved by the superintendent and mounted on the widest part of the towed vehicle so as to be visible from the front and sides of the vehicle. No reflector can have a piece broken from its reflective surface, but may have one or more cracks. Taping or gluing cracks or pieces is not permitted.
9. Any passenger vehicle is equipped with clearance lamps, unless such lamps are used to mark the extreme width of the vehicle or used as taxicab identification, or used as supplemental turn signals. (See 19VAC30-70-190 B.)
10. Vehicles so constructed as to make compliance with the requirements of subdivisions 1, 5, 7, 9, 11, and 12 of this section impractical will be equipped with clearance lamps and reflectors at the most practical location to provide maximum visibility.
11. Any vehicle is not equipped with two front side marker lights (amber) and two rear side marker lights (red).
12. Any vehicle is not equipped with two front side reflectors (amber), two rear side reflectors (red), and two reflectors mounted on the rear (red).

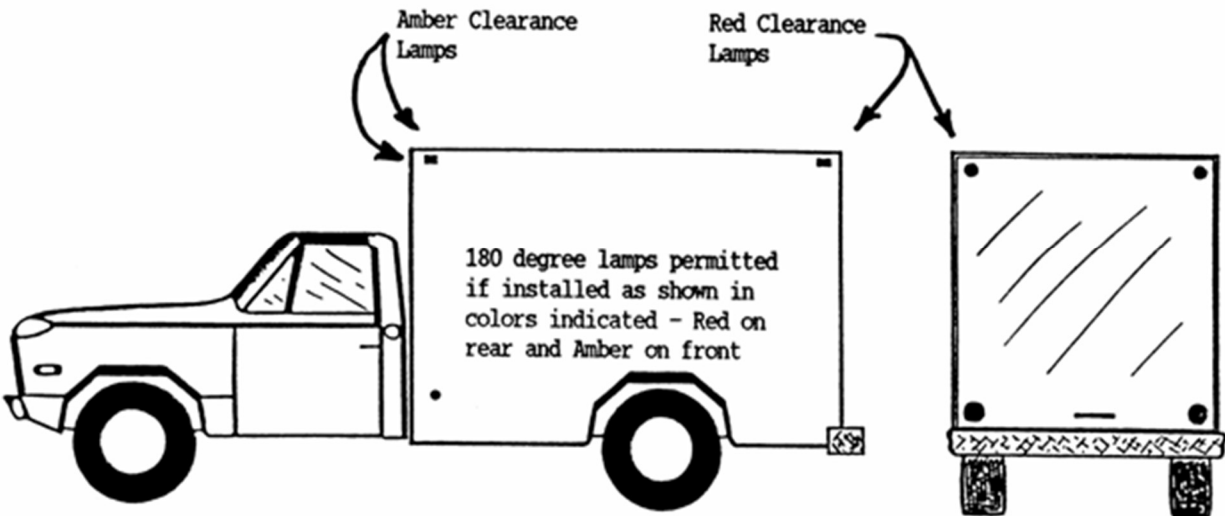

If equipped with three clearance lamps may be mounted at any height so long as they indicate, as nearly as practicable, the extreme width of the vehicle.

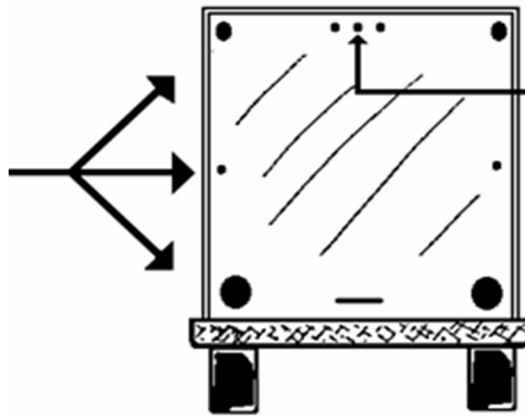

NOTE: Must have lamps, required identification

ILLUSTRATIONS FOR PROPER INSTALLATION OF REFLECTORS

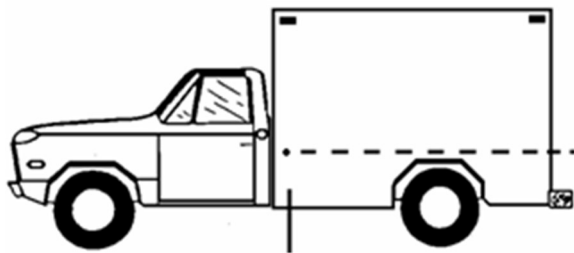

At least 15 inches and not more than 60 inches from the ground.

Amber Reflector

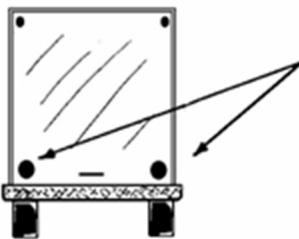

Red Reflectors: At least 15 inches and not more than 60 inches from the ground.

19VAC30-70-190. Signal device (intention to stop or turn), hazard lights, stop lamp.

- A. Any motor vehicle may be equipped with a switch that will permit all turn signal lamps to flash simultaneously.
- B. Supplemental turn signals, properly wired into the turn signal circuit, may be installed. These may be either approved type turn signals or clearance lamps.
- C. Single face lamps are permissible on the front, except tractor units shall be equipped with two-faced lamps mounted on the front fenders or on or near the front of the vehicle.
- D. Inspect for and reject if:
 - 1. Motor vehicle, or trailer, except an antique vehicle not originally equipped with a stop lamp, is not equipped with at least two brake lights of an approved type (DOT or SAE-S) that automatically exhibits a red or amber light to the rear when the brake pedal is actuated.
 - 2. Every passenger car manufactured for the 1986 or subsequent model year and multipurpose passenger vehicle, truck, or bus whose overall width is less than 80 inches, manufactured September 1, 1993, and subsequent model year is not equipped with a supplemental center high mount stop lamp of an approved type (DOT or SAEU, U1 or U2) mounted at the vertical centerline of the vehicle which functions only in cooperation with the vehicle's stop lamps, brake lights and hazard lights. Any other vehicle on which a supplemental center high mount stop lamp is mounted shall have the lamp mounted at the vertical center line of the vehicle. The lamps shall be of an approved type and shall function only in conjunction with the stop lamps. The high mount stop lamp must be steady burning and not wired to flash with turn signals or other wig-wag device.

“Multipurpose passenger vehicle” means any motor vehicle that is (i) designed to carry no more than 10 persons and (ii) constructed either on a truck chassis or with special features for occasional off-road use.

NOTE: Camper shells or rear spoilers that obscure the original manufacturer's high mount stop lamp must be equipped with a center high mount stop lamp in good working order.

NOTE: The original manufacturer's center high mount stop lamp will not be considered for inspection if it is obscured by a camper shell or rear spoiler that is equipped with a center high mount stop lamp of an approved type.

NOTE: No sticker or other foreign material shall be affixed to the vehicle in such a manner so as to obscure the center high mount stop lamp.

- 3. Proper signals do not go on with each throw of the switch or if stop signals do not go on with slightest pressure on the brake pedal. Turn signals may flash, however stop signals may not flash except when the vehicle is equipped with a brake warning system or device which will cause the brake lights to flash when the vehicle is in motion but committed to an emergency or panic stop.
- 4. Motor vehicle was manufactured after January 1, 1955, and is not equipped with approved signaling devices (SAE-I).

5. Vehicle is not equipped with a turn signal if such signal is not working properly or does not continue to function in the same manner as when it was originally manufactured. (The turn signal switch shall lock in place when positioned for a left turn or a right turn, and the turn signal indicators must function. Do not reject a vehicle if the self-canceling mechanism in the switch does not function when the steering wheel is rotated.).
6. Switch is not convenient to the driver and not of an approved type.
7. Any vehicle so constructed so as to prevent the operator from making a hand and arm signal, if such vehicle is not equipped with an approved type signaling device.
8. Turn signal lens is not clear or amber to the front, or red or amber to the rear. Lens or bulb color has been altered or modified. If the turn signal lens is clear, then the bulb shall be amber.

NOTE: The pink color lens found on 1998 and 1999 Honda Accords emit the proper color light (amber) when the lamp is activated. There may be other manufacturers using the same configuration and are not in violation of the Federal Motor Vehicle Safety Standards.

9. Wiring or electrical connections are defective or filaments do not burn.

NOTE: LED (light-emitting diode) lights with a clear lens are acceptable if of an approved type. For those vehicles that are equipped with a multiple LED light (not filament-burning bulbs), they will pass inspection if more than 50% of the diode lights are burning.

10. Lens has a piece broken from it. The lens may have one or more cracks provided an off-color light does not project through the cracks. Taping or gluing cracks or pieces is not permitted.
11. The hazard warning signal operating unit does not operate independently of the ignition or equivalent switch and when activated cause all turn signals to flash simultaneously.

NOTE: They are deemed not to be installed if none of the lights burn or flash when the switch is activated and the hazard warning signal flasher unit has been removed.

12. Device is not mounted near the rear for rear signals or near the front for front signals (except supplemental turn signals) or if the signal is hidden by a bolster or other part of body chassis.
13. All "Class A" signals are not mounted at least three feet apart. (This does not apply to the combination rear signal device.) However, signal lamps that are mounted as far apart as practical inside and at the rear of the frame so as to be properly visible will meet inspection requirements.
14. Any vehicle has wire, unapproved lens or plastic covers, any other materials that are not original equipment or any colored material placed on or in front of the signal device (intention to stop or turn), hazard lights or stop lamp.

19VAC30-70-200. Permissible lighting equipment.

A. Any vehicle may be equipped with:

1. Running board or courtesy lamps, of not over six candlepower.
2. Vacant or destination signs, if a taxicab or bus.
3. Identification lamps of approved type (SAE -P2 or P-3).
4. Interior lights, of not more than 15 candlepower.

Exception: This does not apply to alternating, blinking or flashing colored emergency lights mounted inside law-enforcement vehicles or flashing shielded red or red and white lights, mounted inside vehicles owned by members of volunteer fire companies, volunteer rescue squads or owned or used by professional firefighters, or police chaplains. Also, this does not apply to firefighting vehicles equipped with map lights.

5. Hood ornament light if of an approved type or permitted by the superintendent.
6. Any approved lamp in good working order when used for the purpose for which it was approved.

B. Side marker lamps are not required. If installed they must operate and be inspected. If the bulb, socket and wiring are removed from an individual lamp unit, the unit will not be considered during inspection. This does not include wraparound tail/marker lamp assembly/lens, which is intended to perform multiple functions.

C. Inspect for and reject if:

1. Lamps are not of an approved type (DOT or SAE-P2 or P3), or do not comply with subsection A of this section;
2. Lamps are not installed on the permanent structure of the vehicle with one as far to the rear and one as far forward as practicable and at a location which is not less than 15 inches above the road surface when measured from the center of the lamp;
3. Lamps installed on the side to the rear do not have a red approved lens (SAE-P2). Lamps installed on the side of the front do not have a clear or amber approved lens (SAE-P2) so as to project an amber light. If the approved lens on the front side is clear, then the bulb shall be a DOT-approved amber bulb;
4. Lens has a piece broken from it. The lens may have one or more cracks provided no off-color light projects through the crack(s);
5. Any vehicle has wire, unapproved lens or plastic covers, any other materials which are not original equipment or any colored material placed on or in front of permissible lighting equipment;
6. Wiring or electrical connections are defective or filaments do not burn.
7. LED (light-emitting diode) lights with a clear lens are acceptable if of an approved type. For those vehicles that are equipped with a multiple LED light (not filament-burning bulbs), they will pass inspection if more than 50% of the diode lights are burning.

19VAC30-70-210. Glass and glazing.

A. Motor vehicles may be inspected without windshields, side glasses, or any kind of glazing, except that any motor vehicle other than a motorcycle that was manufactured, assembled, or reconstructed after July 1, 1970, must be equipped with a windshield. If glass or other glazing is installed, it must be inspected. If no windshield is installed, see 19VAC30-70-50 C for location of the sticker.

B. Inspect for and reject if:

1. Any motor vehicle manufactured or assembled after January 1, 1936, or any bus, taxicab or school bus manufactured or assembled after January 1, 1935, is not equipped throughout with safety glass, or other safety glazing material. (This requirement includes slide-in campers used on pickups or trucks, caps, or covers used on pickup trucks, motor homes, and vans.)
2. Any safety glass or glazing used in a motor vehicle is not of an approved type and properly identified (refer to approved equipment section). (Replacement safety glass installed in any part of a vehicle other than the windshield need not bear a trademark or name, provided the glass consists of two or more sheets of glass separated by a glazing material, and provided the glass is cut from a piece of approved safety glass, and provided the edge of the glass can be observed.)

NOTE: A number of 1998 and 1999 model year Ford Contour/Mystique, Econoline and Ranger vehicles were produced without the AS-1 windshield marking as required by FMVSS #205. Ford has certified that these vehicles' windshields meet all performance standards and will not be rejected.

3. Any glass at any location where glass is used is cracked or broken so that it is likely to cut or injure a person in the vehicle.
4. Windshield has any cloudiness more than three inches above the bottom, one inch inward from the outer borders, one inch down from the top, or one inch inward from the center strip. The bottom of the windshield shall be defined as the point where the top of the dash contacts the windshield.
5. Any distortion or obstruction that interferes with a driver's vision; any alteration that has been made to a vehicle that obstructs the driver's clear view through the windshield.
 - a. Any hood scoop installed on any motor vehicle manufactured for the year 1990 or earlier model year cannot exceed 2-1/4 inches high at its highest point measured from the junction of the dashboard and the windshield.
 - b. Any hood scoop installed on any motor vehicle manufactured for the 1991 or subsequent model year cannot exceed 1-1/8 inches high at its highest point measured from the junction of the dashboard and the windshield.

NOTE: Vehicles up to 10,000 pounds (GVWR) submitted for inspection, with a navigational device, video event recording device, or a crash avoidance camera mounted on the interior of the windshield; when the entire device is outside the area swept by the windshield wipers or any location above the AS-1 line, shall be issued an approval sticker if no other violations are detected.

6. Windshield glass, on the driver's side, has any scratch more than 1/4 inch in width and six inches long within the area covered by the windshield wiper blade, excluding the three inches above the bottom of the windshield. A windshield wiper that remains parked within the driver's side windshield wiper area shall be rejected.

EXCEPTION: Do not reject safety grooves designed to clean wiper blades if the grooves do not extend upward from the bottom of the windshield more than six inches at the highest point.

7. There is a pit, chip, or star crack larger than 1-1/2 inches in diameter at any location in the windshield above the three-inch line at the bottom.
8. At any location in the windshield above the three-inch line at the bottom (as measured from the junction of the dash board and the windshield) there is more than one crack from the same point if at least one of the cracks is more than 1-1/2 inches in length. There is any crack that weakens the windshield so that one piece may be moved in relation to the other. (If there is more than one crack running from a star crack that extends above the three-inch line, the windshield shall be rejected.)

NOTE: Windshield repair is a viable option to windshield replacement. However, the primary focus of windshield repairs is to stop or reduce further damage from roadway adversities, vibrations, ambient temperature changes, and weather. Repairs to minor damage may be made so long as the windshield meets all of the standards set forth in this section.

9. Any sticker is on the windshield other than an official one required by law or permitted by the superintendent. Authorization is hereby granted for stickers or decals, to include those required by any county, town, or city, measuring not more than 2-1/2 inches in width and four inches in length to be placed in the blind spot behind the rear view mirror. The normal location for any required county, town, or city sticker is adjacent to the right side of the official inspection sticker when viewed from inside the vehicle. The top edge of the sticker is to be approximately four inches from the bottom of the windshield. The left side edge adjacent to the official inspection sticker shall not be more than 1/4 inch from the right edge of the official inspection sticker when viewed from inside the vehicle. Valid Commercial Vehicle Safety Alliance (CVSA) inspection decals or similar commercial vehicle inspection decal issued by local law enforcement may be placed at the bottom right corner of the windshield when viewed from inside the vehicle. The top edge of such decals are to be approximately four inches from the bottom of the windshield when viewed from inside the vehicle and are to be located outside the area swept by the windshield wipers.

Any sticker or decal required by the laws of any other state or the District of Columbia and displayed upon the windshield of a vehicle submitted for inspection in this state is permitted by the superintendent, provided the vehicle is currently registered in that jurisdiction, and the sticker is displayed in a manner designated by the issuing authority and has not expired. This includes vehicles with dual registration; (i.e., Virginia and the District of Columbia).

NOTE: Toll transponder devices may be affixed to the inside center of the windshield at the roof line just above the rear view mirror. If space does not allow, then the transponder device may be affixed to the immediate right of the mirror at the roof line.

NOTE: A licensed motor vehicle dealer may apply one transponder sticker no larger than one inch by four inches and one barcode sticker no larger than three inches by four inches to the driver's side edge of a vehicle's windshield to be removed upon the sale or lease of the vehicle provided that it does not extend below the AS-1 line. In the absence of an AS-1 line the sticker cannot extend more than five inches downward from the top of the windshield.

NOTE: Any vehicle displaying an expired sticker or decal on its windshield at the time of inspection, excluding a rejection sticker, shall not be issued an approval sticker unless the owner or operator authorizes its removal. A rejection sticker will be issued versus an involuntary removal.

10. Sunshading material, words, lettering, numbers or pictures on the windshield extend below the AS-1 line or five inches downward from the top of the windshield in the absence of an AS-1 line. Sunshading is permitted on the windshield if authorized by the Virginia Department of Motor Vehicles and indicated on the vehicle registration, or a government-leased/owned, law enforcement-use vehicle.

NOTE: Vehicles with permitted sunshading on the windshield must have a cut-out to accommodate the direct application of an approval or rejection sticker to the windshield in the location indicated in 19VAC30-70-50 C or 19VAC30-70-60 E.

NOTE: Vehicles with logos made into the glass at the factory meet federal standards and will pass state inspection.

11. Any sunscreening material is scratched, distorted, wrinkled or obscures or distorts clear vision through the glazing.
12. Front side windows have cloudiness above three inches from the bottom of the glass or other defects that affect the driver's vision or one or more cracks that permit one part of the glass to be moved in relation to another part. Wind silencers, breezes or other ventilator adaptors are not made of clear transparent material.

EXCEPTION: Colored or tinted ventvisors that do not exceed more than two inches from the forward door post into the driver's viewing area are permitted.

13. Glass in the left front door cannot be lowered so a hand signal can be given. (This does not apply to vehicles that were not designed or manufactured for the left front glass to be lowered, provided the vehicle is equipped with approved turn signals.) If either front door has the glass removed and material inserted in place of the glass that could obstruct the driver's vision.

EXCEPTION: Sunscreening material is permissible if the vehicle is equipped with a mirror on each side.

14. Any sticker or other obstruction is on either front side window, rear side windows, or rear windows. (The price label, fuel economy label and the buyer's guide required by federal statute and regulations to be affixed to new or used vehicles by the manufacturer shall normally be affixed to one of the rear side windows.) If a vehicle only has two door windows, the labels may be affixed to one of these windows. If a vehicle does not have any door or side windows the labels may be temporarily affixed to the right side of the windshield until the vehicle is sold to the first purchaser.

NOTE: A single sticker no larger than 20 square inches in area, if such sticker is totally contained within the lower five inches of the glass in the rear window if a vehicle has only one outside mirror, a single sticker or decal no larger than 10 square inches located in an area not more than three inches above the bottom and not more than eight inches from the rearmost edge of either front side window, is permissible and should not be rejected.

A single sticker issued by the Department of Transportation to identify a physically challenged driver, no larger than two inches by two inches, located not more than one inch to the rear of the front door post, or one inch to the rear of the front ventilator glass, if equipped with a ventilator glass and no higher than one inch from the bottom of the window opening, is permitted on the front driver's side window on a vehicle specially equipped for the physically challenged.

15. Rear window is clouded or distorted so that the driver does not have a view 200 feet to the rear.

EXCEPTIONS: The following are permissible if the vehicle is equipped with a mirror on each side:

- a. There is attached to one rear window of such motor vehicle one optically grooved clear plastic right angle rear view lens, not exceeding 18 inches in diameter in the case of a circular lens or not exceeding 11 inches by 14 inches in the case of a rectangular lens, which enables the operator of the motor vehicle to view below the line of sight as viewed through the rear window.
- b. There is affixed to the rear side windows, rear window, or windows of such motor vehicle any sticker or stickers, regardless of size.
- c. There is affixed to the rear side windows, rear window, or windows of such motor vehicle a single layer of sunshading material.
- d. Rear side windows, rear window, or windows is clouded or distorted.

19VAC30-70-220. Mirrors.

Inspect for and reject if:

1. Any motor vehicle is not equipped with at least one mirror.
2. Any 1969 and subsequent model motor vehicle, designed and licensed primarily for passenger vehicular transportation, is not equipped with at least one outside and one inside rear view mirror.

NOTE: The inside mirror cannot be removed on these vehicles even if it has an outside on each side.

Vehicles equipped with only one outside mirror must have the mirror on the driver's side.

EXCEPTION: No multipurpose vehicle shall be required to be equipped with an inside rear view mirror if it does not have a rear window or if the rear window is so obstructed as to prevent rearward vision by means of an inside rear view mirror, if the motor vehicle has horizontally and vertically adjustable outside rear view mirrors installed on both sides of such motor vehicle in such a manner as to provide the driver of such motor vehicle a clear view along both sides of such motor vehicle for a distance of not less than 200 feet.

3. Reflecting surface of mirror is cracked, broken, peeled, pitted, clouded, tarnished, has sharp edges, reflects more than one image or a distorted image, or is not mounted securely.
4. Mirror does not give the driver a clear view of the road 200 feet to the rear.
5. Interior rear view mirror.
 - a. Mirror is loose enough that rear view is impaired.
 - b. Mirror cannot be adjusted or will not maintain a set adjustment.
6. Exterior rear view mirror.
 - a. Mirror is loose enough that rear view is impaired.
 - b. Left mirror is obscured by an unwiped portion of windshield or mirror is mounted so it cannot be adjusted from driver's seat. (Applies to 1969 and subsequent model vehicles.)
 - c. A right side mirror is not required if the reflecting surface of the mirror has been completely removed from the mirror housing; however, a vehicle will be required to have two outside mirrors if there is a sticker or stickers, regardless of size, sunshading or tinting film on the rear side windows or rear window.

NOTE: A single sticker no larger than 20 square inches, if such sticker is totally contained within the lower five inches of the glass of the rear window and does not obstruct the center high mount brake light, is allowed and will pass inspection.

19VAC30-70-230. Windshield wiper; defroster.

A. Windshield wiper.

Inspect for and reject if:

1. Vehicle is equipped with a windshield and is not equipped with a windshield wiper.
2. Vehicle was manufactured before January 1, 1943, and is not equipped with at least one wiper on the driver's side. This wiper may be operated by hand.
3. Vehicle was manufactured after January 1, 1943, and is not equipped with a windshield wiper or wipers that clear both sides of the windshield. Vehicles converted from dual wipers to a single wiper are acceptable provided it continues to clear both sides of the windshield. These wipers must be mechanically operated by electric, vacuum, or air, but not by hand. A switch in good working order and convenient to the driver must be present to turn the wipers on and off. Any wiper that parks within the area covered by the driver's windshield wiper blade, excluding the three inches above the bottom of the windshield shall be rejected. (See 19VAC30-70-210 B 6).
4. Blade has brittle worn, torn or ripped rubber or if metal comes in contact with the windshield; blade is not securely attached to wiper arm.
5. Wiper does not operate freely; or if it is an electrically or mechanically operated wiper which must be operated by hand.

NOTE: Inspect only wipers found on the front windshield. Rear or other wipers will not be considered.

B. Windshield defroster. Vehicles manufactured after January 1, 1969, must be equipped with windshield defroster systems.

Inspect for and reject if:

1. Any 1969 or subsequent model is not equipped with a windshield defroster system;
2. Defroster fan fails to function;
3. Fan functions, but a warm stream of air cannot be felt blowing against the windshield. Engine must be warm and all elements of the defroster system must be in the on position. Switch is not convenient to the driver and working properly.

19VAC30-70-240. Horns and other warning devices.

Inspect for and reject if:

1. Vehicle is not equipped with a horn in good working order, capable of emitting a sound audible under normal conditions over a distance of not less than 200 feet and is not firmly mounted.
2. A horn operating mechanism installed at a location readily accessible to the vehicle operator is not provided. Electrically operated horn, wiring, or electrical connections are defective.

19VAC30-70-250. Doors.

Inspect for and reject if:

1. If each door located at the left and right side of the driver's seat is not equipped with an opening device similar to that installed by vehicle manufacturers that will permit the opening of the door from the outside and inside of the vehicle.

NOTE: A door opening device on customized vehicles may be converted to either a remote, push button or other similar opening switch.

2. If each door located to the left and right side of the driver's seat is not equipped with a latching system similar to that installed by vehicle manufacturers which will hold the door in its proper closed position.

19VAC30-70-260. Hood latch system.

- A. "Hood" means any exterior movable body panel forward of the windshield that is used to cover an engine, luggage, storage or battery compartment.
- B. Inspect for and reject if:
 - 1. Each hood is not provided with a hood latch system that will securely hold the hood in its proper fully-closed position.
 - 2. A latch release mechanism or its parts are broken, missing or badly adjusted so that the hood cannot be opened and closed properly.

NOTE: The hood latch release inside the passenger compartment is only for security and shall not be rejected under this section. If the hood latch cable can be accessed from either the inside or outside of the vehicle and opened by pliers or similar method, then it will pass.

- 3. Latching system on a vehicle equipped with a tilt cab is defective, broken, missing, or not properly adjusted so that the tilt cab is held securely when it is in its latched position.
- C. Battery mounting and storage. Inspect for and reject if:
 - 1. A battery is not securely attached to a fixed part of the motor vehicle or trailer. A battery is not protected by a removable cover or enclosure if the battery is installed in a location other than the engine compartment.
 - 2. All brackets, hardware, bolts, and bushings used for securely mounting the battery to the vehicle are not present.
 - 3. Removable covers or enclosures are not substantial and are not securely latched or fastened.
 - 4. The battery compartment does not have openings to provide ample battery ventilation and drainage.
 - 5. Whenever the cable to the starting motor passes through a metal compartment, the cable shall be protected against grounding by an acid and waterproof insulating bushing.
 - 6. Whenever a battery and a fuel tank are both placed under the driver's seat, (i) the battery and fuel tank are not partitioned from each other or (ii) each compartment is not provided with an independent cover, ventilation, and drainage.

19VAC30-70-270. Floor pan.

Inspect for and reject if:

1. The floor pan or inner side panels, front or rear, are rusted out or have any holes other than normal drain holes that allow exhaust gases to enter the occupant compartment or trunk.
2. The floor pan is rusted through or is in such condition to create a hazard to the occupants. A hole in the floor pan which has been properly repaired by welding, or through the utilization of a metal patch riveted, screwed or welded to its surface is not prohibited. If the floor pan was initially constructed from wood, it may be patched with wood.

19VAC30-70-280. Seat.

Inspect for and reject if:

1. Any motor vehicle is not equipped with a seat to accommodate the operator.
2. The seat is not securely anchored.
3. Seat adjusting mechanism slips out of set position or the seat back will not lock in the proper upright position. Do not reject if it will not adjust as long as it does not violate subdivision 4 of this section.
4. The seat is not located to permit the operator to have adequate control of the steering and braking mechanisms and other instruments necessary for the safe operation of the motor vehicle.

19VAC30-70-290. Seat belts; definitions.

A. Definitions:

“Bus” means a motor vehicle with motive power designed to carry more than 10 persons.

“Designated seating position” means any plain view (looking down from the top) location intended by the manufacturer to provide seating accommodations while the vehicle is in motion, except auxiliary seating accommodations as temporary or folding jump seats.

“Front outboard designated seating positions” means those designated seating positions for the driver and outside front seat passenger (except for trucks which have the passenger seat nearest the passenger side door separated from the door by a passageway used to access the cargo area).

“GVWR” means Gross Vehicle Weight Rating as specified by the manufacturer (loaded weight of a single vehicle).

“Multi-purpose passenger vehicle” means any motor vehicle that is (i) designed to carry no more than 10 persons and (ii) constructed either on a truck chassis or with special features for occasional off-road use. This shall include a mini-van.

“Open-body type vehicle” means a vehicle having no occupant compartment top or an occupant compartment top that can be installed or removed by the user at his/her convenience.

“Passenger car” means a motor vehicle with motive power except a multipurpose passenger vehicle or motorcycle designed for carrying 10 persons or less.

“Rear outboard front facing designated seating positions” means those designated seating positions for passengers in outside front facing seats behind the driver and front passenger seat, except any designated seating position adjacent to a walk-way, that is located between the seat and the near side of the vehicle and is designated to allow access to more rearward seating positions.

“Truck” means a motor vehicle with motive power designed primarily for the transportation of property or special purpose equipment.

B. Passive Restraint System

1. Inflatable occupant restraint (commonly known as air bags).
2. Passive belt system (automatic deployment around the occupant after the occupant enters the vehicle and closes the door).

C. Inspect for and reject if:

1. Not of an approved type; (see approved equipment section for seat belts)
2. Installation not in compliance as follows:
 - a. All motor vehicle seat belt anchorages and attachment hardware must meet the standards and specifications set forth by the Society of Automotive Engineers, Inc., and Federal Motor Vehicle Safety Standard No. 209 (49 CFR 571.209), for such anchorages and attachment hardware;
 - b. Any questions concerning the proper installation of seat belt assemblies should be directed to the nearest Safety Division office.

3. Any 1963 and subsequent model vehicle, designed and licensed primarily for private passenger use, is not equipped with adult safety lap belts for at least two front seats or a combination of lap belts and shoulder straps or harnesses.
 4. Any passenger car manufactured on or after January 1, 1968, is not equipped with lap/shoulder or harness seat belt assemblies located at the front outboard designated seating positions (except in convertibles) and lap seat belt assemblies located at all other designated seating positions.
 5. Any convertible passenger car manufactured on or after January 1, 1968, does not have a lap seat belt assembly for each designated seating position.
 6. Any passenger car manufactured on or after December 11, 1989, (except convertibles) not equipped with lap/shoulder seat belt assemblies located at all forward facing rear outboard designated seating positions.
 - a. Any passenger car manufactured on or after September 1, 1991, (including convertibles) is not equipped with a lap/shoulder seatbelt assembly located at all forward facing rear outboard designated seating positions.
 - b. Any truck, multipurpose vehicle, or bus (except school buses and motor homes) with a gross vehicle weight rating (GVWR) of 10,000 pounds or less, manufactured on or after September 1, 1991, is not equipped with a lap/shoulder seatbelt assembly at all forward facing rear outboard designated seating positions.
 - c. Any of the heretofore described vehicles manufactured on or after September 1, 1992, are not equipped with lap/shoulder seatbelt assembly located at all forward facing rear outboard designated seating positions on a readily removable seat.
 7. Any of the following motor vehicles manufactured on or after July 1, 1971, do not have a lap seat belt assembly for each designated seating position:
 - a. Open-body type vehicles;
 - b. Walk-in van type trucks;
 - c. Trucks (GVWR in excess of 10,000 pounds);
 - d. Multipurpose passenger vehicles (GVWR in excess of 10,000 pounds).
 8. Any buses manufactured on or after July 1, 1971, do not have a lap seat belt assembly for the driver's seating position.
 9. All other motor vehicles manufactured on or after January 1, 1976, except those for which requirements are specified in subdivisions 3 and 4 of this subsection, do not have lap/shoulder or harness seat belt assemblies installed for each front outboard designated seating position. Those vehicles originally equipped and sold by the manufacturer with only a lap belt installed for each designated seating position in compliance with Federal Motor Vehicle Safety Standards (49 CFR Part 571) will be deemed to be in compliance with this section.
 10. Any seat belt buckle, webbing, or mounting is cut, torn, frayed or no longer operates properly.
 11. Any seat belt anchorage is loose, badly corroded, missing or not fastened to belt.
- D. Safety belts (motorized). Enter the vehicle and close the door. Insert the key into the ignition and turn to the on position. A motor causes the shoulder belt to slide along a track (Figure 1) starting at the front body "A" pillar and moving rearward to its locked position at the "B" pillar. The seat belt warning indicator lamp should illuminate with the lap belt unbuckled. When the ignition is

turned to the off position and the door is opened, the shoulder belt moves forward to the “A” pillar.

NOTE: Do not reject if the motor is inoperative and the shoulder belt is permanently “locked” at pillar “B.”

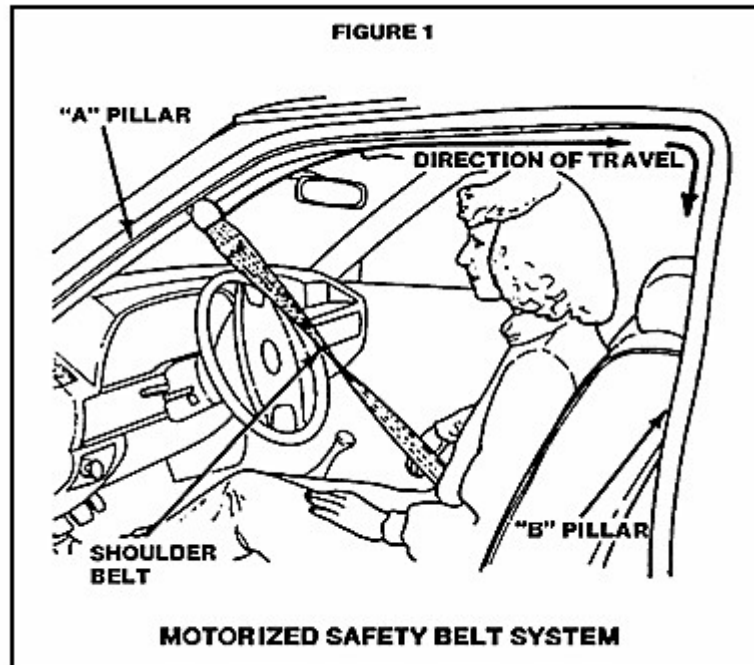

E. Air bag and air bag readiness light.

Inspect for and reject if:

1. Any defects in the air bag system are visible or obvious;
2. The air bag has been deployed and has not been replaced (and is not deactivated because of a medical or other exemption and a notice is posted to indicate that it has been deactivated);
or
3. Any part of the air bag system has been removed from the vehicle.

NOTE: Airbag readiness light check is advisory only and not cause for rejection. Advise customer to make them aware, but do not reject.

19VAC30-70-300. Muffler, exhaust system and trailer venting.

1. Flexible tubing may be used anywhere in the exhaust system.
2. Inspection of exhaust system does not concern noise level.
3. Inspect for and reject if:
 - a. There is any leakage of exhaust gases at any point in the system. Do not reject “built-in” drain holes in muffler or tailpipe.
 - b. A muffler or catalytic converter has been repaired in any manner. The exhaust pipe may be welded to the muffler or catalytic converter. Holes or cracks in the exhaust line have been repaired with a patch or caulking.

NOTE: If a vehicle is inspected that does not have a muffler, the inspector should explain to the customer that although the vehicle will pass inspection without a muffler, it is a violation of state law for the vehicle to be operated on the highway without it.

NOTE: Nissan has designed an exhaust repair for leak or noise at the front tube for the 2002-03 Nissan Pathfinders. The repair may require the application of a specially designed caulk to the front tube of the exhaust system. Since Nissan has designed the repair for their vehicles and trained Nissan technicians would perform the repair, this would be acceptable and should not be rejected. This exception would not preclude the rejection of exhaust systems repaired in a manner that is not designed or approved by the manufacturer and not performed by trained persons.

- c. Tailpipe opening is mashed or pinched.
 - d. Any components of the exhaust system are not properly secured. Brackets or hangers are loose, broken, or missing.
 - e. The exhaust system fails to discharge the exhaust to the rear or sides of the passenger and trunk compartment of passenger vehicles unless such design is consistent with the original vehicle manufacturer exhaust system.
 - f. The exhaust system fails to discharge the exhaust to the rear or sides of the passenger compartment that is designed for and normally used for the driver and passengers of a property-carrying vehicle.
4. Trailers and semitrailer venting. Inspection of trailers and semitrailers will include a visual inspection of the venting of cooking or heating appliances to the outside of the trailer or semitrailer to determine if the heating and cooking appliances are adequately vented to the outside to prevent the asphyxiation of occupants of any trailer or semitrailer by the operation of the heating or cooking appliances.
 - a. Reject the trailer or semitrailer if not equipped with a vent or venting system to the outside.
 - b. Reject the trailer or semitrailer if there is any complete or partial obstruction of the vent or venting system.

NOTE: Exhaust pipes must direct the fumes to exit from underneath of the vehicle to the sides or rear most area.

NOTE: Exhaust pipes must extend behind the cab or rear axle of pickup trucks or utility trucks.

19VAC30-70-310. Air pollution control system or device.

- A. No motor vehicle manufactured for the model year 1973 or for subsequent model years shall be operated on the highways of this Commonwealth unless it is equipped with an air pollution control system or device, or combination of such systems or devices installed in accordance with federal laws and regulations.
- B. The provisions of this section shall not prohibit or prevent shop adjustments or replacements of equipment for maintenance or repair or the conversion of engines to low polluting fuels, such as, but not limited to, natural gas or propane, so long as such action does not degrade in any manner or to any degree the anti-pollution capabilities of the vehicle power system.
- C. Inspect for and reject if:
 - 1. The air pollution control system or device on motor vehicles manufactured for the model year 1973 or for subsequent model years has been removed or otherwise rendered inoperable. The conversion of an engine to utilize low polluting fuels such as natural gas or propane may result in the removal of some part of the pollution control system; however, if the engine is converted to utilize both low polluting fuels and/or gasoline no part of the pollution control system or device can be removed or otherwise rendered inoperable.
 - 2. Any of the essential parts of the pollution control system or devices on vehicles manufactured for the model year 1973 or for subsequent model years have been removed, rendered inoperable or disconnected. This includes any belt, valve, pump, hose line, cap, canister, catalytic converter and the restrictor in the gasoline tank filler neck on vehicles required to use unleaded fuel.

NOTE: In order to determine if a motor vehicle was originally equipped with emissions control equipment, refer to the vehicle's emissions control information label which is usually located in the engine compartment.

- 3. The emission control system or device on motor vehicles manufactured for the model year 1973 or for subsequent model years is not comparable to that designed for use upon the particular vehicle as standard factory equipment.

Any new or used after-market catalytic converter installed on a vehicle after December 31, 1987, shall meet and be installed in accordance with specifications established by the Environmental Protection Agency. A catalytic converter so installed shall be identified with a visible, permanent, nondestructible label or stamp which will identify the manufacturer, vehicle application and month and year of manufacture. The label shall be in accordance with the following format:

- a. New converters - N/XX/YYYY/ZZZZ
- b. Used converters - U/XX/YYYY/ZZZZ

N - New converter designation

U - Used converter designation

XX - Manufacturer code issued by EPA

YYYY - Numerical designation of vehicle application

ZZZZ - Month and year of manufacture (i.e. - 0188 for January, 1988)

19VAC30-70-320. Fuel system.

Inspect for and reject if:

1. Any part of the fuel system is not securely fastened.
2. There is fuel leakage at any point in the fuel system.
3. The fuel tank filler cap is missing.
4. The fuel tank crossover lines are not protected.
5. Any part of the fuel system comes in contact with the exhaust system.
6. Fuel lines or hoses have any cracks, crimps, or restrictions or are abraded, exposing inner fabric.

Part IV
Inspection Requirements for Motorcycles

19VAC30-70-340. Motorcycle brakes.

- A. The inspector, if qualified to operate a motorcycle, must drive it into the inspection lane and test the service brakes. If not qualified to operate motorcycles, the inspector must observe the operator operate the brakes. The inspector is required to observe and inspect the braking system on both wheels if so equipped or required to be equipped.
- B. Inspect for and reject if:
1. Any motorcycle is not equipped with a brake, or which has a disconnected brake.
 2. Any motorcycle which was originally equipped with a service brake system on both the front or rear wheel(s) if the service brake system has been altered by removing or disconnecting any of the brake system components from any of the wheels.
 3. Any motorcycle manufactured after July 1, 1974, is not equipped with either a split service brake system or two independently actuated service brake systems which shall act on the front as well as the rear wheel or wheels.
 4. Bonded linings or disc pads are worn to less than 2/32 of an inch in thickness or riveted linings or disc pads are worn to less than 2/32 of an inch over the rivet head(s).
 5. Any lining is broken or cracked so that the lining or parts of the lining are not firmly attached to the shoe or disc pad.
 6. Grease or any other contamination is present on the brake lining, disc pad, drum or rotor.
 7. Rivets in riveted linings or disc pads are loose or missing.
 8. A brake drum or brake disc (rotor) is scored to the extent that it impairs the braking system.
 9. A brake drum or brake disc is worn beyond the manufacturer's recommended limit. (A brake drum or brake disc shall under no circumstances be remachined beyond the manufacturer's specifications.)
 10. Rods are bent, cotter keys or lock nuts are missing, cables frayed or broken or parts misaligned.
 11. When operated at 20 miles per hour on a dry, level, hard surface free from loose material, the brakes will not stop the motorcycle within 30 feet.
 12. Levers (foot and hand) do not have at least 1/3 of their travel as reserve after brakes are fully applied.
 13. Any leaks in master cylinder, wheel cylinders, or any brake hoses or lines.
 14. A motorcycle that is equipped with a front and rear master cylinder, if one or both are not displaying the recommended manufacturer fluid level.
 15. Any line or hose not installed so as to prevent damage or abrasion by contact with the frame or other components. There is any leakage in any hydraulic, air, or vacuum lines; hoses have any cracks, crimps, restrictions, or are abraded exposing fabric; tubing or connections leak, are crimped, restricted, cracked or broken; any valves leak or are inoperative. Reject the vehicle if the brake hoses or tubing are stretched or extended and do not allow for suspension movement. Brake tubing and hoses must:

- a. Be long and flexible enough to accommodate without damage all normal motions of the parts to which it is attached;
- b. Be secured against chaffing, kinking, or other mechanical damage; and
- c. Be installed in a manner that prevents it from contacting the vehicle's exhaust system or any other source of high temperatures.

19VAC30-70-350. Motorcycle airbag, seat, steering, and suspension.

Inspect for and reject if:

1. Frame is bent or damaged so as to constitute a hazard in proper operation.
2. Wheels are out of line to a degree steering and control is affected.
3. Steering-head bearing is loose, broken, defective or out of adjustment.
4. Handlebars are loose, bent, broken or damaged in such a manner as to affect proper steering.
5. Shock absorbers are broken, worn, missing, defective, disconnected or do not function properly.
6. Any spring in the suspension system is broken or sagging.

NOTE: If a motorcycle or autocycle is equipped or designed with steering or suspension components similar in design to a passenger vehicle, the steering or suspension will be inspected as if the motorcycle or autocycle were a passenger vehicle.

7. If motorcycle seat or seats are not securely fastened.
8. Any motorcycle designed to carry more than one person is not equipped with a footrest for each passenger.
9. The battery is not attached to a fixed part of the motorcycle and protected by a removable cover or enclosure if the battery is installed in a location other than the engine compartment. This includes all brackets, hardware, bolts, and bushings used for securely mounting the battery to the motorcycle.
 - a. Removable covers or enclosures shall be substantial and shall be securely latched or fastened.
 - b. The battery compartment shall have openings to provide ample battery ventilation and drainage.
 - c. Whenever the cable to the starting motor passes through a metal compartment, the cable shall be protected against grounding by an acid and waterproof insulating bushing.
 - d. Whenever a battery and a fuel tank are both placed under the driver's seat, they shall be partitioned from each other and each compartment shall be provided with an independent cover, ventilation, and drainage.
10. Air bag and air bag readiness light. Inspect for and reject if:
 - a. Any defects in the air bag system are noted by the air bag readiness light or otherwise indicated;
 - b. The air bag has been deployed and has not been replaced (and is not deactivated because of a medical or other exemption and a notice is posted to indicate that it has been deactivated);
 - c. Any part of the air bag system has been removed from the motorcycle.
 - d. If the air bag indicator fails to light or stays on continuously.

NOTE: Checking the air bag readiness light. Turn the ignition key to the on position; the air bag readiness light will indicate normal operation by lighting for six to eight seconds, then turning off.

A system malfunction is indicated by the flashing or continuous illumination of the readiness light or failure of the light to turn on.

NOTE: Any motorcycle not originally manufactured with an air bag readiness light shall not be rejected for not having this item.

19VAC30-70-360. Motorcycle Lights, Auxiliary, Headlamp, Rear, Signal, Warning.

A. Headlamps. Inspect for and reject if:

1. Motorcycle is not equipped with at least one motorcycle headlamp.
2. Any motorcycle headlamp is not of an approved type (SAE-M). A motorcycle may have one or more headlamps. In addition to the headlamp or headlamps, a motorcycle may be equipped with not more than two auxiliary headlamps of a type approved (SAE-C) by the superintendent and identified as "auxiliary front lamps."
3. Lens and reflector do not match except in sealed units, or if the lens is cracked, broken or rotated, or if the lens and reflector are not clean or bright.
4. Any motorcycle lights-headlamp, rear lamp, signal or warning lamp has any wire, unapproved lens or plastic covers, any other materials that are not original equipment or any colored material placed on or in front of lamp or lens.
5. Lamp is not focused or any filament or bulb fails to burn.
6. Lamp is not mounted securely or if switch does not operate properly.
7. The center of the hot spot is set more than four inches up or down from the horizontal centerline or more than four inches to the left or right from the vertical centerline. Inspectors shall rely on their education, training, and experience to determine if the headlamp is properly aimed. If improper alignment is observed, the headlamp shall be checked for proper aim by using an optical headlamp aimer.
8. The high beam indicator does not burn when the high beam is on or does not go off when the low beam is on.

NOTE: Motorcycles may be equipped with means of modulating the high beam of their headlights between high and low beam at a rate of 200 to 280 flashes per minute, provided they are equipped with a switch or device that prevents flashing of headlights when headlights are required to be lighted.

NOTE: Inspection is to be performed with lamp on high beam.

NOTE: The use of strobe lights being placed inside the headlamps of police motorcycles is permitted. The strobe light system developed by Harley-Davidson for use in police motorcycle headlamps has been tested and does meet the current standard; therefore, strobe light systems of this type and similar types may be used in police motorcycle headlamp systems.

B. Aiming the headlamp. All headlamps that do not comply with subdivision A 7 of this section shall be aimed straight ahead. (Zero inches up or down and zero inches to the right or left.)

C. Rear lamp. Inspect for and reject if:

1. The motorcycle is not equipped with a rear lamp of approved type (SAE-T-S-P-A).
2. The lamp is not mounted near rear of vehicle, or is not mounted securely, or if lamp does not make a good electrical connection.

3. Lenses are not red to the rear and clear or amber to the front or any lens has a piece broken from it. The lens may have one or more cracks provided an off-color light does not project through the cracks.

NOTE: LED (light-emitting diode) lights with a clear lens are acceptable if of an approved type. For motorcycles equipped with a multiple LED light (not filament-burning bulbs), they will pass inspection if more than 50% of the diode lights are burning.

4. Filaments in all lamps do not burn when headlamp switch is turned on to any position.
5. The rear license plate is not illuminated by an approved license plate bulb.

D. Signal device (intention to stop or turn).

1. Signal devices are not required on motorcycles; however, if installed, they must operate and be inspected.
2. Signal lamp lenses installed on the front of the motorcycle shall be amber and be located on each side of the vertical centerline of the motorcycle and as far apart as practicable and not closer than nine inches, measured from the optical centerline of the lamps, and to be located on the same level and not less than 20 inches above the ground level. The optical centerline of the lamp shall not be less than four inches from the retaining ring of the headlamp unit.
3. Signal lamps installed on the rear of the motorcycle shall be red or amber and shall be located on each side of the vertical centerline of the motorcycle as far apart as practicable but not closer than nine inches, measured from the optical centerline of the lens, and shall be located on the same level and not less than 20 inches above the ground level.
4. Inspect for and reject if:
 - a. Motorcycle, except an antique vehicle not originally equipped with a stop lamp, is not equipped with at least one stop lamp of an approved type that automatically exhibits a red or amber light to the rear when the brake control foot pedal or hand grip brake control device is activated. (On motorcycles manufactured prior to January 1, 1972, the activation of the front wheel brake control device is not required to activate the stop lamp.)

NOTE: Motorcycles may be equipped with a means of varying the brightness of the vehicle's brake light upon application of the vehicle's brakes.

- b. The signal lamp is not of an approved type (SAE-D) or does not flash.
- c. Lens in brake lamp or signal lamp has a piece broken from it. (Lens in brake lamp or signal lamp may have one or more cracks provided an off-color light does not project through the crack or cracks.)
- d. Wiring or electrical connections are defective or any filaments do not burn.
- e. Switch is not convenient to the driver and not of an approved type.
- f. Signal devices are not installed as provided in subdivisions D 1, 2, and 3 of this section.

E. Warning lights. Inspect for and reject if:

1. Warning lamps are not of an approved type or have been altered.
2. Any lighted advertising sign is present.

F. Auxiliary lights. Inspect for and reject if:

1. Motorcycle or autocycles are equipped with any color other than red or amber standard bulb running lights or light-emitting diode (LED) pods or strips.
2. Auxiliary lights are not directed toward the ground.
3. Auxiliary lights are not designed for vehicular use.
4. Auxiliary lights project a beam of light greater than 25 candlepower per bulb.
5. Auxiliary lights display a blinking, flashing, oscillating, or rotating pattern.
6. Auxiliary lights are attached to the wheels.

NOTE: Such lighting is not subject to approval by the Superintendent of the State Police.

19VAC30-70-370. Motorcycle mirror.

Inspect for and reject if:

1. Motorcycle is not equipped with a mirror.
2. Reflecting surface of mirror is cracked, broken, peeled, pitted, clouded, tarnished, has sharp edges, or reflects more than one image or a distorted image.
3. Mirror is not mounted securely.
4. Operator does not have a view of the road 200 feet to the rear.

19VAC30-70-380. Motorcycle horn.

Inspect for and reject if:

1. Motorcycle is not equipped with a horn in good working order capable of emitting sound audible under normal conditions for a distance no less than 200 feet.
2. Horn is not mounted securely, wiring is defective, control button is not operating properly, or is not installed at a location readily accessible to the operator.

19VAC30-70-390. Motorcycle muffler and exhaust system.

Inspect for and reject if:

1. Vehicle has no exhaust line or tailpipe if the system is designed for same.
2. A muffler has been repaired with a jacket, a patch or in any other manner.
3. Vehicle has installed a muffler cutout or bypass.
4. Any components of the exhaust system are not properly secured.
5. Leakage of gases is noted at manifold gaskets, muffler and muffler connections, or at any point in the exhaust line.
6. Tailpipe opening is pinched or mashed.

NOTE: If a vehicle is inspected that does not have a muffler, the inspector should explain to the customer that although the vehicle will pass inspection without a muffler, it is a violation of state law for the vehicle to be operated on the highway without it.

19VAC30-70-400. Motorcycle tires, wheels, rims.

Inspect for and reject if:

1. Any tire has a cut or puncture, not to include a plug or patch that may be used as a manner of repair, or is worn so that the fabric is visible.

NOTE: Plugs/patches shall be in the tread area only. Plugs/patches are not permitted in the side wall of the tire.

2. Any tire has knots or bulges in any side wall or if there is evidence of a broken belt under the tread or of the tread separating from the fabric.
3. Any bolts, nuts, lugs or spokes are bent, loose or missing. Rims or wheels are bent, cracked or damaged so as to affect the safe operation of the motorcycle.
4. Wheel bearings are excessively worn or out of adjustment.
5. Any motorcycle is equipped with a tire that has a tread depth measuring less than $\frac{2}{32}$ of an inch when measured in accordance with the instructions set forth in subdivisions 6, 7, and 8 of 19VAC30-70-130.
6. Any tire is marked specifically for use other than on the highway such as "For Farm Use Only," "For Off-Highway Use Only," "For Mobile Home Use Only," or "For Trailer Use Only."
7. Any motorcycle tire has been recut or regrooved.
8. Directional tires or wheels designed and manufactured to go in a certain direction or rotation are not installed in the proper direction of rotation.

19VAC30-70-410. Motorcycle windscreen and glazing.

Inspect for and reject if:

1. Any windscreen is not of an approved type.
2. Any windscreen obstructs the driver's vision.
3. Any decal, support, or installation component interferes with the driver's vision.

19VAC30-70-420. Motorcycle fuel system.

Inspect for and reject if:

1. Any part of the fuel system is not securely fastened.
2. There is fuel leakage at any point in the fuel system.
3. The fuel tank filler cap is missing.

Part V
Inspection Requirements for Trucks and Other
Vehicles Over 10,000 Pounds (GVWR)

19VAC30-70-430. Inspection -- heavy vehicles.

A. Inspection procedure -- heavy vehicles:

1. Remove existing inspection sticker (all vehicles).
2. While in right front, inspect right side glass and right side lug nuts, windshield, seat belts, and door latches.
3. Drive vehicle into inspection lane.
4. While in driver's seat, check left side glass and window crank, windshield, driver's seat, seat belts, door latches and parking or holding brake. Check service brake, high beam indicator, turn signal switch, air brake low air warning, air pressure loss, (single/combo) horn, windshield wiper, defroster, mirrors, steering lash and floor pan.
5. Check exhaust system and fuel tank.
6. Check right side marker and clearance reflectors.
7. Check all rear lights (including brake and turn signal). Check all rear reflectors.

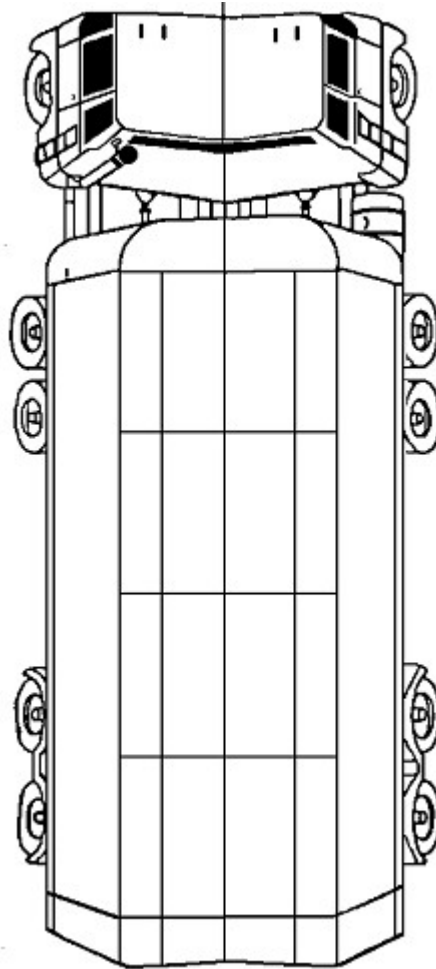

8. Check left side marker, clearance lights and reflectors.
9. Check all wheels for brakes, push rod travel, tires, rims and suspension.
10. Check headlights, fog, driving, turn signals, other lights and reflectors.
11. Check steering system, ball joints/king pin, shocks, springs.
12. Open hood and check latching mechanism, master cylinder, engine mounts, and compressor belts.
13. Check frame (all vehicles) and coupling device.
14. Check air lines and couplings. Disconnect emergency air line (red) (left) and check for automatic operation of trailer breakaway brakes. Check tractor air protection valve. (Combination vehicle only).
15. Issue approval or rejection sticker.

B. Inspection guidelines. Required lamps and reflectors on commercial vehicles.

Lamps and reflex reflectors. Table 1 specifies the requirements for lamps, reflective devices and associated equipment by the type of commercial motor vehicle. The diagrams in this section illustrate the position of the lamps, reflective devices and associated equipment specified in Table 1. All commercial motor vehicles manufactured on or after December 25, 1968, must, at a minimum, meet the applicable requirements.

Table 1 Required Lamps and Reflectors on Commercial Motor Vehicles Greater Than 26,000 Pounds GVWR						
Item on the vehicle	Quantity	Color	Location	Position	Height above the road surface in millimeters (mm) (with English units in parenthesis) measured from the center of the lamp at curb weight	Vehicles for which the devices are required
Headlamps	2	White	Front	On the front at the same height, with an equal number at each side of the vertical center line as far apart as practicable.	Not less than 559 mm (22 inches) nor more than 1,372 mm (54 inches)	A, B, C
Turn signal (front) ^{2, 12}	2	Amber	At or near the front	One on each side of the vertical centerline at the same height and as far apart as practicable.	Not less than 381 mm (15 inches) nor more than 2,108 mm (83 inches.)	A, B, C
Identification lamps (front) ¹	3	Amber	Front	As close as practicable to the top of the vehicle, at the same height, and as close as practicable to the vertical centerline of the vehicle (or the vertical centerline of	All three on the same level as close as practicable to the top of the motor vehicle.	B, C

				the cab where different from the centerline of the vehicle) with lamp centers spaced not less than 152 mm (6 inches) or more than 305 mm (12 inches) apart. Alternatively, the front lamps may be located as close as practicable to the top of the cab.		
Tail lamps ^{5, 11}	2	Red	Rear	One lamp on each side of the vertical centerline at the same height and as far apart as practicable.	Both on the same level between 381 mm (15 inches) and 1,829 mm (72 inches).	A, B, C, D, E, F, G, H
Stop lamps ^{5, 13}	2	Red	Rear	One lamp on each side of the vertical centerline at the same height and as far apart as practicable.	Both on the same level between 381 mm (15 inches) and 1,829 mm (72 inches).	A, B, C, D, E, F, G
Clearance lamps ^{8, 9, 10, 15, 17}	2	Amber	One on each side of the front of the vehicle	One on each side of the vertical centerline to indicate overall width.	Both on the same level as high as practicable.	B, C, D, G, H

	2	Red	One on each side of the rear of the vehicle	One on each side of the vertical centerline to indicate overall width.	Both on the same level as high as practicable.	B, D, G, H
Reflex reflector, intermediate (side)	2	Amber	One on each side	At or near the midpoint between the front and rear side marker lamps, if the length of the vehicle is more than 9,144 mm (30 feet).	Between 381 mm (15 inches) and 1,524 (60 inches).	A, B, D, F, G
Reflex reflector (rear) ^{5, 6, 8}	2	Red	Rear	One on each side of the vertical centerline, as far apart as practicable and at the same height.	Both on the same level, between 381 mm (15 inches) and 1,524 mm (60 inches).	A, B, C, D, E, F, G
Reflex reflector (rear side)	2	Red	One on each side (rear)	As far to the rear as practicable.	Both on the same level, between 381 mm (15 inches) and 1,524 mm (60 inches).	A, B, D, F, G
Reflex reflector (front side) ¹⁶	2	Amber	One on each side (front)	As far to the front as practicable.	Between 381 mm (15 inches) and 1,524 mm (60 inches).	A, B, C, D, F, G
License plate lamp (rear) ¹¹	1	White	At rear license plate to illuminate the plate from the top or sides	As far to the front as practicable.	No requirements	A, B, C, D, F, G

Side marker lamp (front) ¹⁶	2	Amber	One on each side		Not less than 381 mm (15 inches).	A, B, C, D, F
Side marker lamp intermediate	2	Amber	One on each side	At or near the midpoint between the front and rear side marker lamps, if the length of the vehicle is more than 9,144 mm (30 feet).	Not less than 381 mm (15 inches).	A, B, D, F, G
Side marker lamp (rear) ^{4, 8}	2	Red	One on each side	As far to the rear as practicable.	Not less than 381 mm (15 inches), and on the rear of trailers not more than 1,524 mm (60 inches).	A, B, D, F, G
Turn signal (rear) ^{5, 12}	2	Amber or red	Rear	One lamp on each side of the vertical centerline as far apart as practicable.	Both on the same level, between 381 mm (15 inches) and 2,108 mm (83 inches).	A, B, C, D, E, F, G
Identification lamp (rear) ^{3, 7, 15}	3	Red	Rear	One as close as practicable to the vertical centerline. One on each side with lamp centers spaced not less than 152 mm (6 inches) or more than 305 mm (12 inches) apart.	All three on the same level as close as practicable to the top of the vehicle.	B, D, G

Vehicular hazard warning signal flasher lamps ^{5, 12}	2	Amber	Front	One lamp on each side of the vertical centerline, as far apart as practicable.	Both on the same level, between 381 mm (15 inches) and 2,108 mm (83 inches).	A, B, C
	1 or 2	Amber or red	Rear	One lamp on each side of the vertical centerline, as far apart as practicable.	Both on the same level, between 381 mm (15 inches) and 2,108 mm (83 inches).	A, B, C, D, E, F, G
Backup lamp ¹⁴	1 or 2	White	Rear	Rear	No requirement	A, B, C
Parking lamp	2	Amber or white	Front	One lamp on each side of the vertical centerline, as far apart as practicable.	Both on the same level, between 381 mm (15 inches) and 2,108 mm (83 inches).	A

Legend: Types of commercial motor vehicles shown in the last column of Table 1:

- A. Buses and trucks less than 2,032 mm (80 inches) in overall width.
- B. Buses and trucks 2,032 mm (80 inches) or more in overall width.
- C. Truck tractors.
- D. Semi-trailers and full trailers 2,032 mm (80 inches) or more in overall width except converter dollies.
- E. Converter dolly.
- F. Semi-trailers and full trailers less than 2,032 mm (80 inches) in overall width.
- G. Pole trailers.
- H. Projecting loads.

Note: Lamps and reflectors may be combined as permitted by equipment combinations.

NOTES: ¹Identification lamps and reflectors may be mounted on the vertical centerline of the cab where different from the centerline of the vehicle, except where the cab is not more than 42 inches wide at the front roofline, then a single lamp at the center of the cab shall be deemed to comply with the requirements for identification lamps. No part of the identification lamps or their mountings may extend below the top of the vehicle windshield.

²Unless the turn signals on the front are so constructed (doubled-faced) and located as to be visible to passing drivers, two turn signals are required on the rear of the truck tractor, one at each side as far apart as practicable.

³The identification lamps need not be visible or lighted if obscured by a vehicle in the same combination.

⁴Any semitrailer or full trailer manufactured on or after March 1, 1979, shall be equipped with rear side-marker lamps at a height of not less than 381 mm (15 inches), and on the rear of the trailers not more than 1,524 mm (60 inches) above the road surface, as measured from the center of the lamp on the vehicle at curb weight.

⁵Each converter dolly, when towed singly by another vehicle and not as part of a full trailer, shall be equipped with one stop lamp, one tail lamp, and two reflectors (one on each side of the vertical centerline, as far apart as practicable) on the rear. Each converter dolly shall be equipped with rear turn signals and vehicular hazard warning signal flasher lamps when towed singly by another vehicle and not as part of a full trailer, if the converter dolly obscures the turn signals at the rear of the towing vehicle.

⁶Pole trailers shall be equipped with two reflex reflectors on the rear, one on each side of the vertical centerline as far as practicable, to indicate the extreme width of the trailer.

⁷Pole trailers, when towed by motor vehicles with rear identification lamps and mounted at a height greater than the load being transported on the pole trailer, are not required to have rear identification lamps.

⁸Pole trailers shall have on the rearmost support for the load: (1) two front clearance lamps, one on each side of the vehicle, both on the same level and as high as practicable to indicate the overall width of the pole trailer; (2) two rear clearance lamps, one on each side of the vehicle, both at the same level and as high as practicable to indicate the overall width of the pole trailer; (3) two rear side marker lamps, one on each side of the vehicle, both on the same level, not less than 375 mm (15 inches) above the road surface; (4) two rear reflex reflectors, one on each side, both on the same level, not less than 375 mm (15 inches) above the road surface to indicate maximum width of the pole trailer; and (5) one red reflector on each side of the rearmost support for the load. Lamps and reflectors may be combined.

⁹Any motor vehicle transporting a load that extends more than 102 mm (4 inches) beyond the overall width of the motor vehicle shall be equipped with the following lamps in addition to other required lamps when operated during the hours when headlamps are required to be used.

(1) The foremost edge of that portion of the load that projects beyond the side of the vehicle shall be marked (at its outermost extremity) with an amber lamp visible from the front and side.

(2) The rearmost edge of that portion of the load that projects beyond the side of the vehicle shall be marked (at its outermost extremity) with a red lamp visible from the rear and side.

(3) If the projecting load does not measure more than 914 mm (3 feet) from front to rear, it shall be marked with an amber lamp visible from the front, both sides, and rear, except that if the projection is located at or near the rear it shall be marked by a red lamp visible from front, side, and rear.

¹⁰Projections beyond rear of motor vehicles. Motor vehicles transporting loads that extend more than 1,219 mm (4 feet) beyond the rear of the motor vehicle, or that have tailboards or tailgates extending more than 1,219 mm (4 feet) beyond the body, shall have these projections marked as follows when the vehicle is operated during the hours when headlamps are required to be used:

(1) On each side of the projecting load, one red side marker lamp, visible from the side, located so

as to indicate maximum overhang.

(2) On the rear of the projecting load, two red lamps, visible from the rear, one at each side; and two red reflectors visible from the rear, one at each side, located so as to indicate maximum width.

¹¹To be illuminated when tractor headlamps are illuminated.

¹²Every bus, truck, and truck tractor shall be equipped with a signaling system that, in addition to signaling turning movements, shall have a switch or combination of switches that will cause the two front turn signals and the two rear signals to flash simultaneously as a vehicular traffic signal warning. The system shall be capable of flashing simultaneously with the ignition of the vehicle on or off.

¹³To be actuated upon application of service brakes.

¹⁴Backup lamp required to operate when bus, truck, or truck tractor is in reverse.

¹⁵(1) For the purposes, the term "overall width" refers to the nominal design dimension of the widest part of the vehicle, exclusive of the signal lamps, marker lamps, outside rearview mirrors, flexible fender extensions, and mud flaps.

(2) Clearance lamps may be mounted at a location other than on the front and rear if necessary to indicate the overall width of a vehicle, or for protection from damage during normal operation of the vehicle.

(3) On a trailer, the front clearance lamps may be mounted at a height below the extreme height if mounting at the extreme height results in the lamps failing to mark the overall width of the trailer.

(4) On a truck tractor, clearance lamps mounted on the cab may be located to indicate the width of the cab, rather than the width of the vehicle.

(5) When the rear identification lamps are mounted at the extreme height of a vehicle, rear clearance lamps are not required to be located as close as practicable to the top of the vehicle.

¹⁶A trailer subject to this part that is less than 1,829 mm (6 feet) in overall length, including the trailer tongue, need not be equipped with front side marker lamps and front side reflex reflectors.

¹⁷A boat trailer subject to this part whose overall width is 2,032 mm (80 inches) or more need not be equipped with both front and rear clearance lamps provided an amber (front) and red (rear) clearance lamp is located at or near the midpoint on each side so as to indicate its extreme width.

19VAC30-70-440. Service brakes.

- A. The inspector, at a minimum, must drive all vehicles into the inspection lane and test both service and parking brakes, except vehicles the inspector is not qualified to drive. In these cases, the inspector will ride in the vehicle and observe the application of the brakes.
- B. A minimum of one wheel or one wheel and drum or dust cover must be removed from each vehicle at the time of inspection except vehicles having open brake mechanisms that will permit the inspection of the brake lining, or discs and disc pads, without removing the wheel and rim.

WARNING: Failure to properly torque lug nuts may cause severe damage to the wheel.

The inspection receipt (approval and rejection) shall be marked to reflect which wheel and drum or dust cover was removed or inspected.

- C. If any braking problem is detected, the inspector may test drive or require a test drive of the vehicle.
- D. Inspect for and reject if:
 - 1. Any commercial motor vehicle manufactured on or after October 20, 1994, is equipped with an air brake system but is not equipped with the proper and functioning automatic brake adjuster system and brake adjuster indicator.
 - 2. Vehicles equipped with air brakes: when the air brake adjustment on vehicles is equal to or exceeds values in the following tables for cam brakes or brake shoe travel is greater than 1/16" on wedge brakes when measured according to Illustrations #1 and #2. (See procedure in addition to illustrations.)

TABLE 1 MINIMUM CRITERIA FOR BRAKE ADJUSTMENT COMMERCIAL VEHICLE SAFETY ALLIANCE NORTH AMERICAN STANDARD OUT-OF-SERVICE CRITERIA Brake adjustment shall not exceed those specifications contained hereunder relating to "Brake adjustment limit." (Dimensions are in inches.)		
CLAMP TYPE BRAKE CHAMBER DATA		
Type	Outside Diameter	Brakes Exceeding the Maximum Brake Adjustment Limit Shall be Readjusted
6	4-1/2 (114mm)	1-1/4 (32mm)
9	5-1/4 (133mm)	1-3/8 (35mm)
12	5-11/16 (145mm)	1-3/8 (35mm)
16	6-3/8 (162mm)	1-3/4 (45mm)

20	6-25/32 (172mm)	1-3/4 (45mm)
24	7-7/32 (184mm)	1-3/4 (45mm)
30	8-3/32 (206mm)	2.0 (51mm)
36	9.0 (229mm)	2-1/4 (57mm)

NOTE: A brake found at the adjustment limit is not to be rejected.

LONG STROKE CLAMP TYPE BRAKE CHAMBER DATA

Type	Outside Diameter	Brakes Exceeding the Maximum Brake Adjustment Limit Shall be Readjusted
12	5-11/16 (14.5mm)	1-3/4 (45mm)
16	6-3/8 (162mm)	2.0 (51mm)
20	6-25/32 (172mm)	2.0 (51mm)
24	7-7/32 (184mm)	2.0 (51mm)
24*	7-7/32 (184mm)	2.5 (64mm)
30	8-3/32 (206mm)	2.5 (64mm)

*For 3" maximum stroke type 24 chambers

NOTE: A brake found at the adjustment limit is not to be rejected.

NOTE: 3" long stroke brake chambers are identified by square air line ports and a trapezoidal tag attached to the chamber.

BOLT TYPE BRAKE CHAMBER DATA

Type	Outside Diameter	Brakes Exceeding the Maximum Brake Adjustment Limit Shall be Readjusted
A (12)	6-15/16 (176mm)	1-3/8 (35mm)
B (24)	-3/16 (234mm)	1-3/4 (45mm)
C (16)	8-1/16 (205mm)	1-3/4 (45mm)
D (6)	5-1/4 (133mm)	1-1/4 (32mm)

E (9)	6-3/16 (157mm)	1-3/8 (35mm)
F (36)	11.0 (279mm)	2-1/4 (57mm)
G (30)	9-7/8 (251mm)	2.0 (51mm)
NOTE: A brake found at the adjustment limit is not to be rejected.		
ROTOCHAMBER DATA		
Type	Outside Diameter	Brakes Exceeding the Maximum Brake Adjustment Limit Shall be Readjusted
9	4-9/32 (109mm)	1-1/2 (38mm)
12	4-13/16 (122mm)	1-1/2 (38mm)
16	5-13/32 (138mm)	2.0 (51mm)
20	5-15/16 (151mm)	2.0 (51mm)
24	6-13/32 (163mm)	2.0 (51mm)
30	7-1/16 (180mm)	2-1/4 (57mm)
36	7-5/8 (194mm)	2-3/4 (70mm)
50	8-7/8 (226mm)	3.0 (76mm)
NOTE: A brake found at the adjustment limit is not to be rejected.		
DD-3 BRAKE CHAMBER DATA		
Type	Outside Diameter	Brakes Exceeding the Maximum Brake Adjustment Limit Shall be Readjusted
30	8-1/8 (206mm)	2-1/4 (57mm)
NOTE: This chamber has three air lines and is found on motor coaches. NOTE: A brake found at the adjustment limit is not to be rejected.		
WEDGE BRAKE DATA		
The combined movement of both brake shoe lining scribe marks shall not exceed 1/8 inch (3.18mm).		

PROCEDURE FOR MEASURING CAM AND WEDGE BRAKES AND HOW TO PROPERLY IDENTIFY 3" LONG STROKE CHAMBERS

On vehicles equipped with cam brakes, mark each brake chamber push rod at the face of the brake chamber with the brakes released. Apply the air brakes fully, minimum air pressure of 90 to 100 psi, and measure the distance the push rod travels from the face of the chamber to the mark previously made when the brakes were released. This measurement is the push-rod stroke (see illustration).

On vehicles equipped with wedge brakes, remove the inspection hole cover at each dust shield and with the brakes released, scribe a line on the edge of the brake lining. Apply the air brakes fully and measure the distance the brake lining travels.

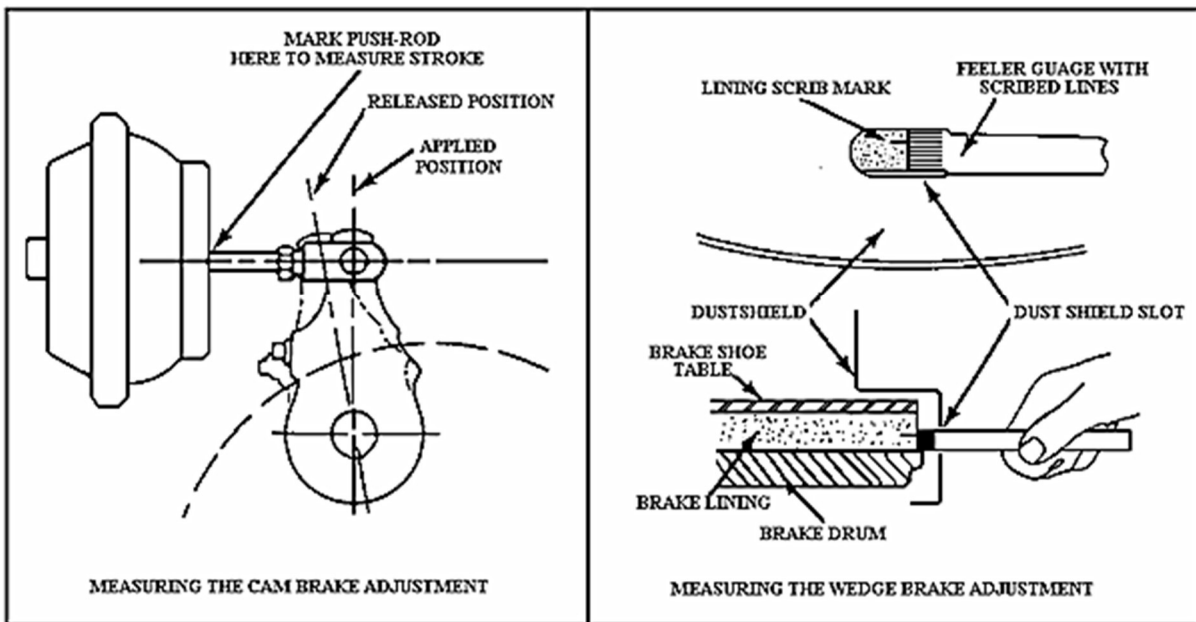

3" Long Stroke Chamber Identification Service Chambers

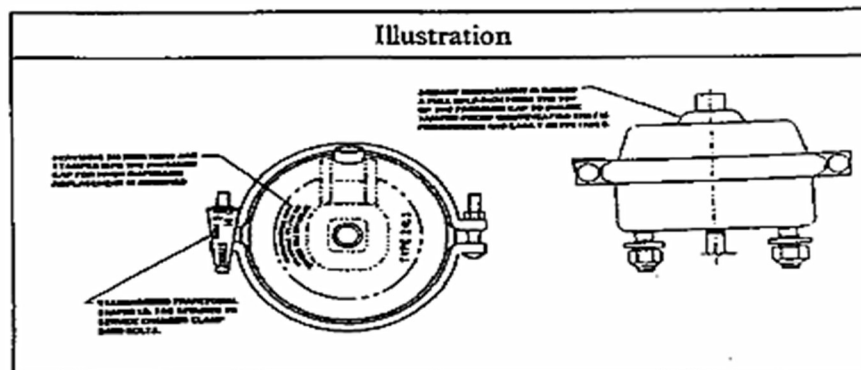

**3" Long Stroke Chamber Identification
Spring Brake Chamber**

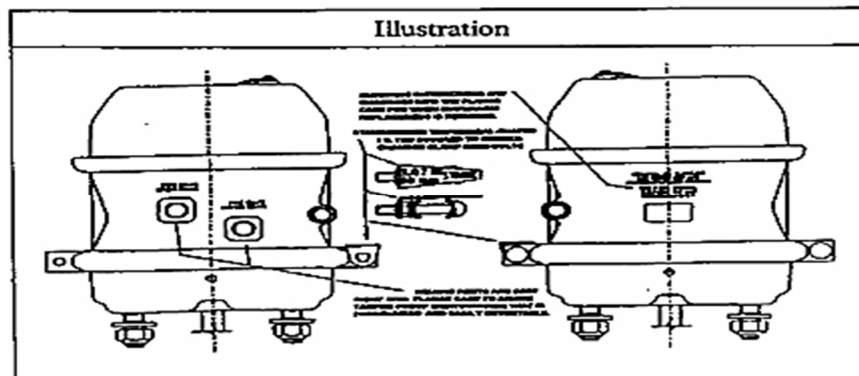

3. Brake hose and tubing. There is any leakage in any hydraulic, air or vacuum lines; hoses have any cracks, crimps, restrictions, or are abraded exposing fabric into second ply of fabric; tubing or connections leak, are crimped, restricted, cracked, or broken.
 - a. Hose with any damage extending through the reinforcement ply. Rubber impregnated fabric cover is not a reinforcement ply. Thermoplastic nylon may have braid reinforcement or color difference between cover and inner tube. Exposure of second color is cause for rejection.
 - b. Bulge or swelling when air pressure is applied.
 - c. Two hoses improperly joined (such as a splice made by sliding the hose ends over a piece of tubing and clamping the hose to the tube).
 - d. Brake tubing and hose must:
 - 1) Be long and flexible enough to accommodate without damage all normal motions of the parts to which it is attached;
 - 2) Be secured against chaffing, kinking, or other mechanical damage; and
 - 3) Be installed in a manner that prevents it from contacting the vehicle's exhaust system or any other source of high temperatures.
 - e. Any hydraulic brake tubing has been repaired using a compression fitting.
4. Service brakes.
 - a. There is less than 1/5 reserve in pedal travel of the service brake when fully applied on all hydraulic, mechanical, or power-assisted hydraulic braking systems.
 - b. When tested on dry, hard, approximately level road free from loose material at a speed of 20 miles per hour without leaving a 12-foot-wide lane, a distance in excess of the following stopping distance is obtained:
 - c. Any bus, truck or tractor - 40 feet;
 - d. All combinations of vehicles - 40 feet.

- e. Every motor vehicle, trailer or semitrailer is not equipped with operational brakes on all wheels (except as shown in subdivision D 4 c (1) of this section) or any brake has been disconnected or rendered inoperative or improperly installed.
 - 1) Road tractors, tractor trucks, or trucks if manufactured prior to July 25, 1980, having three or more axles are not required to have brakes on the steering axle; however, if installed must be inspected and meet all requirements of this section.
 - 2) Missing, bent or broken mechanical components including: shoes, lining pads, spring, anchor pin, spiders, cam rollers, push rods and air chamber mounting bolts, air reservoirs not securely mounted or leaks.
 - 3) Absence of braking action on any axle required to have brakes, upon application of the service brakes (such as missing brakes or brake shoes, failing to move upon application of a wedge, S-cam or disc brake).
 - 4) Loose brake components including air chambers, spiders and cam shaft support brackets.
 - 5) Audible air leak at brake chamber (example: ruptured diaphragm, loose chamber clamp, etc.)
 - f. Linings or pads are broken or cracked so that brake pad is not firmly attached to the shoe or improperly installed or cracks on the friction surface extends to the open edge.
 - 1) Rivets or bolts are loose or missing.
 - 2) Lining or pad friction surface is saturated with oil, grease or brake fluid.
 - g. Nonsteering axles. Lining has a thickness less than 1/4 inch at the shoe center for air drum brakes, 1/16 inch or less at the shoe center for hydraulic and electric drum brakes and less than 1/8 inch for air disc brakes, lining with a thickness less than 3/16 inch for a shoe with a continuous strip of lining or to wear indicators if so equipped.
 - 1) Steering axles. Lining has thickness less than 1/4 inch at the shoe center from drum brakes, less than 1/8 inch for air disc brakes and 1/16 inch or less for hydraulic disc and electric brakes, lining with a thickness less than 3/16 inch for a shoe with a continuous strip of lining or to wear indicators if so equipped.
 - 2) Mismatch across any power unit steering axle of:
 - a. Air chamber sizes.
 - b. Slack adjuster length.
 - h. Thickness of riveted or bolted lining is less than 2/32 of an inch above the rivet or bolt head(s).
 - i. Any lining or pad is misaligned or does not make full contact with the drum or rotor.
5. Brake Drums and Discs.
- a. Brake drums or brake discs (rotors) are worn or scored to the extent that their remachining would result in a failure to meet manufacturer's specifications.

- b. Brake drums or discs with any external crack or cracks that open upon brake application.

NOTE: Do not confuse short hairline heat cracks with flexural cracks.

6. Mechanical linkage.

Any portion of the drum or rotor missing or in danger of falling away.

7. Hydraulic.

NOTE: Some motor vehicles, beginning with 1976 models, have a hydraulic power system that serves both the power assisted brakes and power assisted steering system. Some vehicles, beginning with 1985 models, have an integrated hydraulic actuation and anti-lock brake unit using only brake fluid.

8. Hydraulic System Operation.

Stop engine, then depress brake pedal several times to eliminate all pressure. Depress pedal with a light foot-force (30 pounds). While maintaining this force on the pedal, start engine and observe if pedal moves slightly when engine starts.

Reject vehicle if pedal does not move slightly as engine is started while force is on brake pedal.

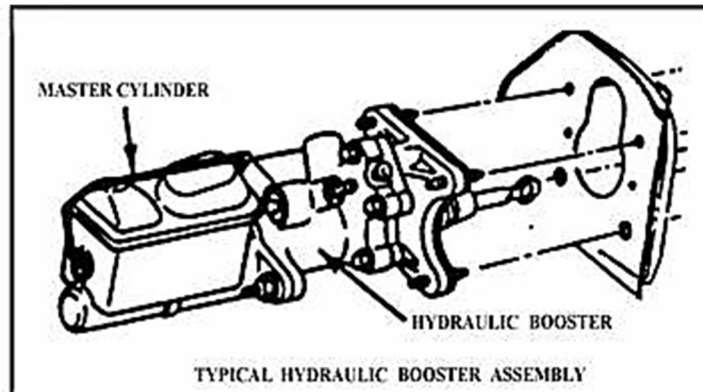

9. Condition of hydraulic booster power brake system.

Inspect system for fluid level and leaks. Reject vehicle if there is insufficient fluid in the power steering pump reservoir; if there are broken, kinked or restricted fluid lines or hoses; if there is any leakage of fluid at the pump, steering gear or brake booster, or any of the lines or hoses in the system; or if belts are frayed, cracked or excessively worn.

10. Integrated hydraulic booster/anti-lock system operation.

With the ignition key in the off position, depress brake pedal a minimum of 25 times to deplete all residual stored pressure in the accumulator. Depress pedal with a light foot-force (25 lbs.). Place ignition key in the on position and allow 60 seconds for the brake warning light to go out and the electric pump to shut off.

Reject vehicle if the brake pedal does not move down slightly as the pump builds pressure or if the brake and anti-lock warning lights remain on longer than 60 seconds.

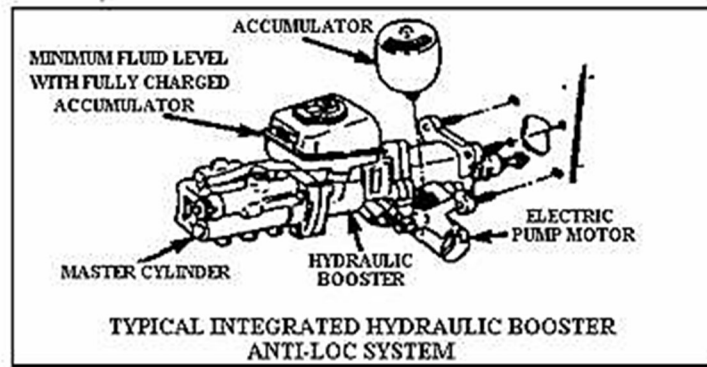

11. Condition of integrated hydraulic booster/anti-lock system with electronic pump.

With the system fully charged, inspect system for fluid level and leaks.

Reject vehicle if there is insufficient fluid in the reservoir; if there are broken, kinked or restricted fluid lines or hoses; or if there is any leakage of fluid at the pump or brake booster, or any of the lines or hoses in the system.

12. Vacuum system operation.

Stop engine then depress brake pedal several times to eliminate all vacuum in the system. Depress pedal with a light foot-force (25 lbs.). While maintaining this force on the pedal, start engine and observe if pedal moves down slightly when engine starts.

Reject vehicle if pedal does not move down slightly as engine is started while force is on the brake pedal. In full vacuum-equipped vehicles, there is insufficient vacuum reserve for one full service brake application after engine is stopped.

- a. Has insufficient vacuum reserve to permit one full brake application after engine is shut off.
- b. Lacks an operative low-vacuum warning device as required.

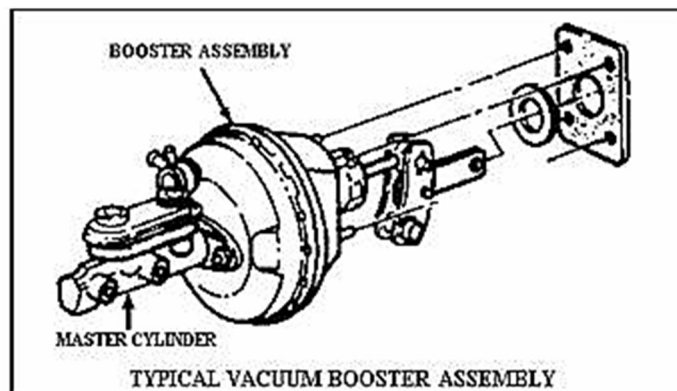

13. Condition of vacuum booster power brake system.

- a. Visual inspection. Reject vehicle if there are collapsed, cracked, broken, badly chafed or improperly supported hoses and tubes, loose or broken hose clamps.
- b. There is any leakage in the hydraulic system. (Do not disturb the dust boot when checking for leaking wheel cylinders.)

- c. Fluid level in master cylinder is below the proper level for the particular vehicle.
 - d. There is any evidence of a caliper sticking or binding.
14. Air brakes.
- a. Motor vehicle is equipped with air brakes and does not have an operating air pressure gauge.
 - b. Any bus, truck, road tractor and tractor truck manufactured after March 15, 1975, must have a visible low air warning device. Those manufactured on or before March 15, 1975, may have either an audible or visible low air warning device.
 - c. Low pressure warning device is missing, inoperative or does not operate at 55 psi and below or 1/2 the governor cut out pressure, whichever is less.
 - d. Compressed air reserve is not sufficient to make one full service brake application after engine is stopped, or with system fully charged, the reservoir pressure is lowered more than 30% by one full brake application.
 - e. Brake chamber push rods do not follow application of service brake pedal, or do not reach full released position (example: defective return spring).
 - f. Any bus, truck, road tractor, or tractor truck manufactured after February 28, 1975, if equipped with a manually operated device to reduce or remove the braking effort upon its front wheels.
15. Electric brakes.
- a. Trailers show an amperage value more than 20% above or 30% below the brake manufacturer's maximum current rating for each brake.
 - b. Ammeter shows no reading or indicator is not steady on application and release of brake controller.
 - c. Any terminal connections are loose or dirty; wires are broken, frayed or unsupported; any single conductor or nonstranded wire or wires below size recommended by brake manufacturers are installed.
 - d. Electrical trailer brakes do not apply automatically when breakaway safety switch is operated.
 - e. Absence of braking action on any wheel required to have brakes.
 - f. Missing or inoperative breakaway braking device; cable is frayed or broken.
16. Air compressor.
- a. Compressor drive belts are in condition of impending or probable failure.
 - b. Loose compressor mounting bolts or compressor leaks.
 - c. Cracked, broken or loose pulley.
 - d. Tractor protection valve(s) is defective or inoperative.
 - e. Air safety relief valve is defective or inoperative.

19VAC30-70-450. Brakes: Emergency Parking or Holding

- A. Some vehicles are equipped with an actual emergency brake, while others have only a parking or holding brake. Some types may be actuated by a foot or hand lever, while others may incorporate a switch or valve to actuate the brake. Air and vacuum brake systems may employ spring activating parking brakes.
- B. Inspect for and reject if:
1. Vehicle or combination of vehicles is not equipped with a parking, holding, or emergency brake in good working order of the type installed as original standard factory equipment for the vehicle on which it is installed.
 2. The brake actuating mechanism does not fully release when the control is operated to the off position.
 3. Any mechanical parts are missing, broken, badly worn, or are inoperative.
 4. Cables are stretched, worn, or frayed or not operating freely.
 5. Parking brake will not hold the vehicle stationary with the engine running at slightly accelerated speed with shift lever in drive position for automatic transmission or shift lever in low gear with clutch engaged for standard shift transmission.
 6. On vehicles equipped with automatic transmissions, the vehicle will start in any gear other than (P) park or (N) neutral. If the gearshift indicator does not identify the park (P) and neutral (N) positions, then the vehicle shall be rejected.
 7. On vehicles equipped with manual transmissions, the vehicle will start in any gear if the clutch is not depressed or disengaged.

NOTE: This will not apply to older vehicles, which were not originally equipped with a neutral-safety switch, clutch disengagement system or clutch pedal position sensor by the manufacturer.

8. Any nonmanufactured hole in the spring brake housing section of a parking brake.

NOTE: All commercial motor vehicles manufactured after March 7, 1990, shall be equipped with a parking brake system adequate to hold the vehicle or combination under any condition of loading except agricultural commodity trailers, converter dollies, heavy haulers and pulpwood trailers.

19VAC30-70-460. Brakes: Trailer (GVWR 10,000 pounds or more).

- A. All trailers and semitrailers having an actual gross weight of 10,000 pounds or more shall be equipped with operational brakes acting on all wheels.
- B. Inspect for and reject if:
 - 1. Trailer brakes do not comply with provisions of 19VAC30-70-430, 19VAC30-70-440 and 19VAC30-70-450.
 - 2. Operator does not have full control over brakes. For the purpose of this subdivision, surge brakes are considered to be in control of the operator.
 - 3. Combination will not stop as required in 19VAC30-70-440 D 5.
 - 4. Breakaway braking devices are missing or inoperative or cable is frayed or broken, or trailers are not equipped with emergency breakaway brakes designed to:
 - a. Apply automatically upon breakaway from towing vehicle.
 - b. Remain fully applied for at least 15 minutes.
 - c. Apply and release by operation of the manual emergency control.
 - d. Apply automatically when the pressure in the towing vehicle reservoir is reduced to a point between 45 and 20 PSI by a series of foot applications, when equipped with air brakes.

NOTE: A minimum of one wheel must be removed from each axle equipped with brakes to inspect the brake components.

Exceptions:

- a. Wheels on trailers equipped with open brake mechanisms are not required to be removed.
- b. The inspection receipt (approval and rejection) shall be marked to reflect which wheel, drum or dust cover was removed or inspected.

19VAC30-70-470. Steering.

Inspect for and reject if:

1. Play at any point in the steering mechanism is excessive. The steering mechanism is unusually tight and binding when turning the steering wheel completely to the right and left. The steering mechanism will not turn in both directions, stop to stop, or steering stops have been removed. On certain model passenger buses, it may be necessary to open the inspection access door to allow visual inspection of the steering shaft universal joints.
2. Power steering is defective and affects adequate steering of the vehicle or fluid level in reservoir is below operating level or if there is an obvious leak of power steering fluid. Do not reject for dampness. Power steering hoses have any cracks, crimps, or restrictions or are abraded, exposing inner fabric; tubing or connections leak or are crimped, restricted, cracked, or broken. Power steering tubing and hoses must be secured against chaffing, kinking, or other mechanical damage and be installed in a manner that prevents contact with the vehicle's exhaust system or any other source of high temperatures. Power steering belt does not have sufficient tension, is frayed, or is missing. The serpentine belt should only be rejected if a chunk of the ribbing is missing or a deep cut or crack exposes the inner fabric of the belt. (Do not reject for the many little surface cracks that appear in the ribs or back.)

NOTE: If the vehicle is equipped with power steering, the engine must be running during testing.

3. Any modification has been made to any part of the steering system that affects proper steering. A repair kit or preventive maintenance kit has been installed on a tie rod end, idler arm, ball joint, or any other part of the vehicle's steering gear.

NOTE: This system requires moving components to be checked for steering wheel lash, loose parts or binding. To properly inspect the power steering components, the engine must be running.

NOTE: The repair kit or preventive maintenance kit usually consists of a small spring and a plastic cap that is placed over the bolt stud of the component and held in place by a retaining nut. There is nothing in this paragraph that prohibits the replacement of parts or components of a motor vehicle's steering gear in order to correct deficiencies in the steering gear.

4. Steering Lash/Travel-Trucks.

Before inspection the vehicle must be placed on a smooth, dry, level surface. For vehicles equipped with power steering, the engine must be running and the fluid level, belt tension and condition must be adequate before testing.

With road wheels in straight ahead position, turn steering wheel until motion can be detected at the front road wheels. Align a reference mark on steering wheel with a mark on a ruler and slowly turn steering wheel in the opposite direction until motion can be detected at the front road wheel. Measure lash at steering wheel. Special lash-checking instruments are also available, measuring free play in inches or degrees. Such instruments should always be mounted and used according to the manufacturer's instructions. With vehicle raised, visually inspect steering linkage, ball studs, tie rod end socket assemblies and all pivot points. On vehicles with power steering, engine must be running.

Reject vehicle if steering wheel movement exceeds:

Steering Wheel Size and Lash

Steering wheel diameter	Manual steering system
16 inches or less	2 inches (51 mm)
18 inches	2 1/4 inches (57 mm)
19 inches	2 3/8 inches (60 mm)
20 inches	2 1/2 inches (64 mm)

Reject vehicle if visual inspection reveals excessive wear and/or looseness in any ball stud, end assembly, pivot point or mechanical linkage.

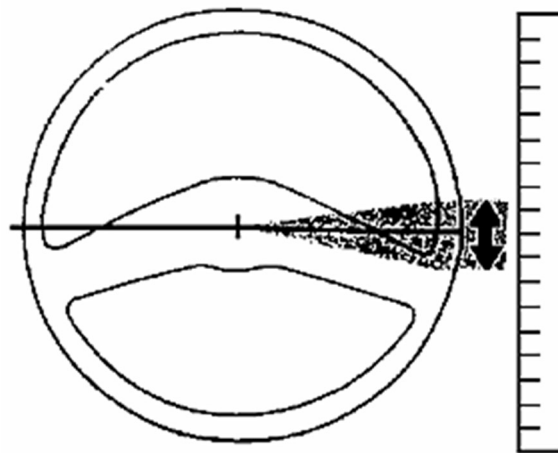

STEERING LASH

5. Any modification or replacement has been made to the steering wheel which affects proper steering. It shall be rejected if it is of a smaller size than the original factory equipment.
6. Steering column has any missing or loose bolts or positioning parts, resulting in motion of the steering column from its normal position. Steering shaft universal joints are loose or exhibit any abnormal movement when shaft is rotated. Any welded repairs are made to the steering system, steering column, steering gear box, pitman arm or universal joints. Any movement of a steering nut under steering load.
7. Any missing or loose bolts or other parts resulting in motion of the steering gear box at the point of attachment to the vehicle's frame.
8. Any looseness of the pitman arm on the steering gear box, output shaft or gear box.
9. Any control arm bushing is missing.
10. Any vehicle equipped with an idler arm shows excessive looseness.
11. Any motion, other than rotational, between any linkage member and its attachment point of more than 1/8 inch measured with hand pressure only.

12. Loose clamps, clamp bolts on tie rod ends or drag links.
13. Any looseness in any threaded joint.
14. Loose or missing nut on tie rods, pitman arm, drag ink, steering arm or tie rod ends.
15. Wheel bearings/steering linkage.
 - a. With the front end of vehicle lifted properly, push pads away from rotor on disc brakes, and grab front tire at top and bottom, rock vigorously in and out and record movement. Wheel bearing looseness is detected by the relative movement between the brake drum or disc and the backing plate or splash shield.
 - 1) Reject vehicle if relative movement between drum and backing plate (disc and splash shield) is more than 1/4 inch measured at the outer circumference of the tire for vehicles more than 10,000 pounds GVWR.
 - 2) Reject vehicle if any wheel bearing is excessively worn or not properly adjusted; any cotter key or other locking device is missing or inoperative.
 - b. Steering linkage play. First eliminate all wheel bearing movement by applying service brake. With vehicle lifted as shown below and wheels in straight ahead position, grasp front and rear of tire and attempt to move assembly right and left without moving the steering gear.

Reject vehicle if measured movement at front or rear of tire is greater than:

Wheel size:	17 inches or less	- 1/4 inch (6.5mm)
	17 to 18 inches	- 3/8 inch (9.5mm)
	over 18 inches	- 1/2 inch (13mm)

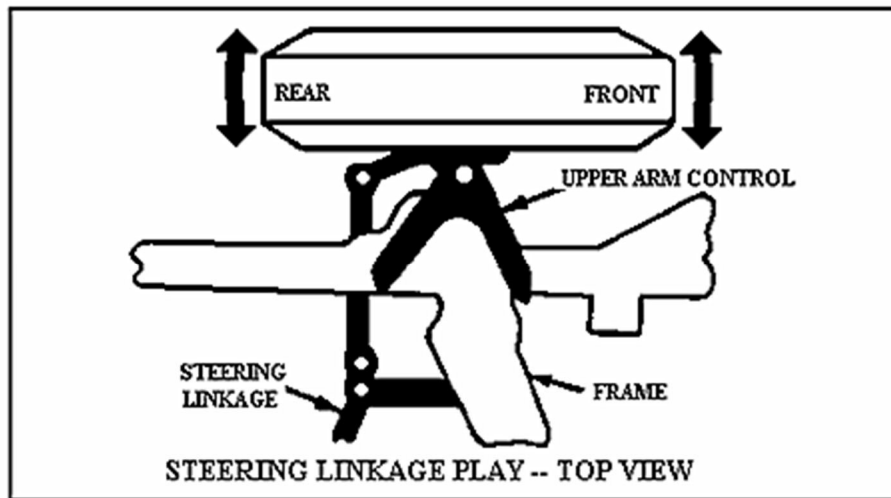

- c. King pin. If vehicle is equipped with king pins, first eliminate all wheel bearing movement by applying service brake. With front end lifted as illustrated for inspecting wheel bearings, (Figure C) grasp the tire at the top and bottom and attempt to move in and out to detect looseness. Measure the movement at the top or bottom of the tire at the outer circumference.

Reject vehicle if measured movement at top or bottom of tire is greater than:

Wheel size:	16 inches or less	- 1/4 inch
	17 to 18 inches	- 3/8 inch
	over 18 inches	- 1/2 inch

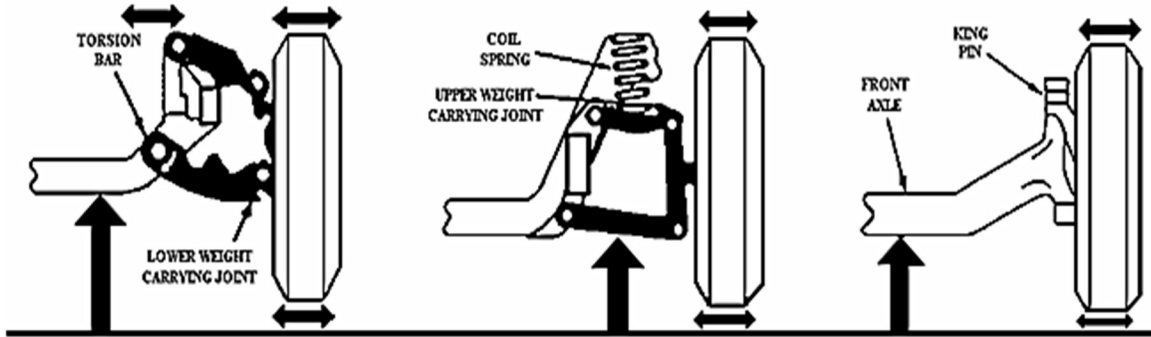

Proper lifting for wheel bearing, steering linkage looseness, and king play action

FIGURE A

FIGURE B

FIGURE C

NOTE: Ball joint wear: There is a trend among U.S. automobile manufacturers toward the use of “wear-indicating” ball joints on light trucks. Many vehicles on the road, however, do not have wear-indicating ball joints. The inspection of both types will be discussed.

Figures 1, 2, 3 and 4 below illustrate the proper hoisting for checking ball joints.

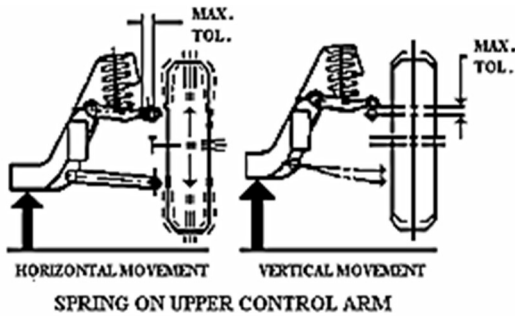

FIGURE 1

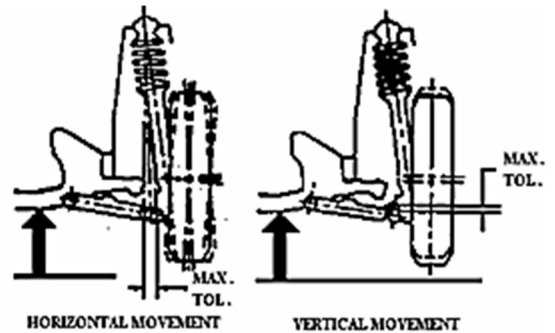

FIGURE 2

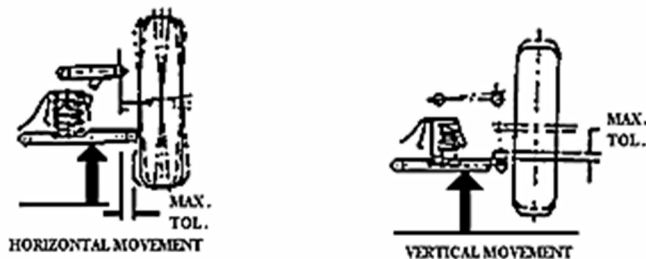

FIGURE 3

RAISING POSITIONS FOR SUSPENSION SYSTEMS

FIGURE 4

NOTE: To check ball joint wear on vehicles when the spring is supported on the upper control arm or when the spring is a part of a MacPherson strut or wear in any other type suspension not using ball joints when the front wheels are suspended on a solid axle, the vehicle must be hoisted as shown in Figure 1 or 2.

NOTE: Upper control arm must be stabilized in normal load carrying position by means of an upper control or other support tool to ensure ball joint is in unloaded position.

NOTE: To check ball joint wear on vehicles not listed in Figures 1 through 4 and diagram or tables when the spring is supported on the lower control arm; and to check the kingpin wear in any other type suspension not previously described when the wheels are independently suspended, the vehicle must be hoisted as shown in Figure 3 or 4.

16. Vehicles without wear indicator ball joint.

- a. If play is detected in any ball joint without “wear-indicating” ball joints, it will be necessary for the inspection to be made in accordance with the manufacturer’s recommended procedures and specifications prior to rejecting the vehicle.
- b. If there are no manufacturer’s recommended procedures and specifications, the lower ball joints will be checked when hoisted as in Figure 1 or 2, or in the upper ball joints when hoisted as in Figure 3 or 4. There should be no noticeable play detected in the ball joints when checked in this manner.
- c. Reject vehicle if play exceeds the manufacturer’s specifications. It is recommended that inspectors use a dial indicator or ball joint checking gauge when checking for play of a ball joint when procedures and specifications are provided by the manufacturer.

17. Ball joints with wear indicators. Support vehicle with ball joints loaded (in normal driving attitude). Wipe grease fitting and checking surface free of dirt and grease. Determine if checking surface extends beyond the surface of the ball joint cover.

Reject vehicle if checking surface is flush with or inside the cover surface.

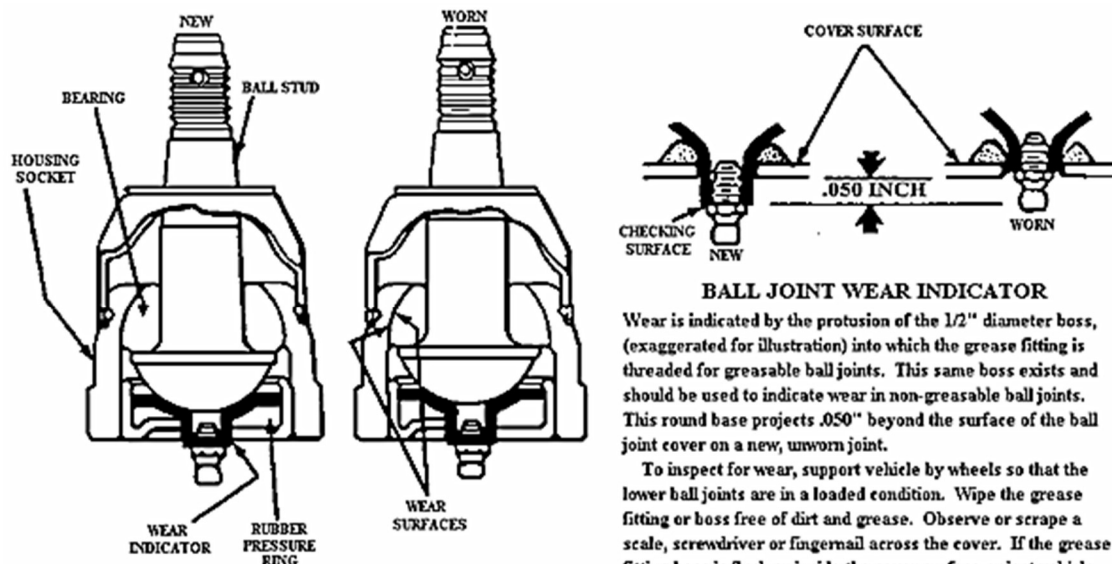

18. Any vehicle inspected in accordance with the recommendation of the manufacturer of such vehicle and found to be within the specification shall be deemed to meet inspection regulations.

19VAC30-70-480. Suspension.

Inspect for and reject if:

1. Any positioning parts are cracked, broken, loose, or missing resulting in shifting of an axle from its normal position.
2. Any part of the torsion bar assembly or torque arm or any part used for attaching the same to the vehicle frame or axle is cracked, broken or missing. NOTE: This does not apply to loose bushing(s) in torque or track arms.
3. Vehicles designed for shock absorbers or cross stabilizer links, if any are missing, disconnected, broken, bent, loose or do not function properly.
4. Any leaf spring is broken, sagging, misaligned, or if spring hangers are worn or loose.
5. Any deflated air suspension system or leaks.

CAUTION: Underneath inspection of a vehicle equipped with air suspension with excessive leakdown could result in serious personal injury.

6. Any suspension system defect or any condition of loading that permits the body or frame to come in contact with a tire or any part of the wheel assemblies.

NOTE: "All thread rod" material shall not be used as U-bolts in the suspension system.

7. Sliding trailer tandem or multi-axle assemblies do not lock in place or have broken or missing parts.
8. Any coil spring is broken.
9. Vehicles with composite springs on either the power unit or trailer, if a crack, regardless of length, is visible on either side, top or bottom.

NOTE: A crack is a separation in any axis that passes completely through the spring.

19VAC30-70-490. Frame, engine mounts, coupling devices and emergency chains and rear impact guards.

A. Inspect for and reject if:

1. Frame of any bus, truck, tractor truck is cracked, loose, broken or sagging. Frame of any trailer or semi-trailer has any broken cracked, loose, or sagging top or bottom frame rails or frame is cracked or broken.
2. Engine, transmission or cab mounts, to include all hardware, bolts, and bushings used to connect the mount to the vehicle, frame, engine, or transmission are broken or missing. Any engine or transmission mount shall be rejected if it allows the power train to come in contact with the firewall or other body parts. Cab mounts should be rejected if they do not properly secure the body to the frame.
3. Trailer hitch or pintle hook is not securely attached. Reject if the pintle eye or trailer drawbar has any cracks or if any welding repairs have been made to the pintle eye.
4. Chains, cables, etc., used to attach a towed vehicle are not securely attached, or are broken, worn or abraded.
5. Fifth wheel does not lock in position or have a locking mechanism that is in proper working order.

NOTE: Reject if horizontal movement exceeds 1/2 inch between upper and lower fifth wheel halves.

6. Fifth wheel assembly system has any leak of fluid or air.
7. Fifth wheel has any broken, missing, or damaged parts; or is not securely attached to the frame. This includes fore and aft stops.
8. Trailer king pin is not secure, or is broken, or worn so as to prevent secure fit in fifth wheel. The upper coupler device is not securely attached.
9. Any cracks, breaks or damaged parts in the stress or load bearing areas of a coupling device.
10. Trailer is not equipped with emergency chains or steel cables.

NOTE: Fifth wheel assembly does not require emergency chain or steel cable. A fifth wheel is defined as a device that interfaces with and couples to the upper coupler assembly of a semitrailer. The upper coupler assembly is a structure consisting of an upper coupler plate, king pin and supporting framework which interfaces with and couples to a fifth wheel. Ball and socket connections also referred to as hitch and coupling connections are not fifth wheel assemblies and do require an emergency chain or steel cable.

11. Sliding trailer tandem or multi-axle assemblies do not lock in place or have worn, broken or missing parts.
12. Any play is detected in the drive shaft u-joints, CV joints, or center load bearing.

- B. **“Rear impact guard” or “guard”** means a device installed on or near the rear of a vehicle so that when the vehicle is struck from the rear, the device limits the distance that the striking vehicle’s front end slides under the rear end of the impacted vehicle.
1. For trailers and semitrailers with a GVWR of 4,536 kg (10,001 lbs.) or more, manufactured on or after January 26, 1998, inspect for and reject if:
 - a. The rear impact guard is missing;
 - b. The guard is not securely attached to the trailer, including broken or missing fasteners, any welds or parent metal is cracked, or other damage is present that compromises the secure attachment of the guard;
 - c. The guard horizontal member does not extend to within 100 mm (4 inches) of each side extremity of the vehicle, or the guard extends beyond either side extremity of the vehicle;
 - d. The guard horizontal member is more than 560 mm (22 inches) above the ground;
 - e. The guard horizontal member is more than 305 mm (12 inches) forward of the rear extremity of the vehicle; or
 - f. The guard horizontal member does not have a cross sectional vertical height of at least 100 mm (4 inches) across its entire width.
 2. For commercial motor vehicles manufactured after December 31, 1952 (except trailers and semitrailers manufactured on or after January 26, 1998), inspect for and reject if:
 - a. The rear impact guard is missing;
 - b. The guard is not securely attached to the trailer by bolts, welding, or other comparable means;
 - c. The guard horizontal member is more than 762 mm (30 inches) above the ground;
 - d. The guard horizontal member does not extend to within 457 mm (18 inches) of each side extremity of the vehicle; or
 - e. The guard horizontal member is more than 610 mm (24 inches) forward of the rear extremity of the vehicle.

19VAC30-70-500. Tires, wheels, rims.

Inspect for and reject if:

1. Any tire is marked specifically for use other than on the highway, such as “For Farm Use Only,” “For Off-Highway Use Only,” any tire marked “Not for Steering Axle,” “For Mobile Home Use Only,” or “For Trailer Use Only.”

EXCEPTION: “For Trailer Use Only” tires are allowed when used on trailers only.

2. A radial tire is mismatched on the same axle with a bias ply tire or a bias belted tire.
3. Bias ply or bias belted tires are used on the rear axle when radial ply tires are used on the front axle. Except:
 - a. On a two-axle vehicle equipped with truck tires with 20-inch rim diameter and larger. Bias or radial tires may be used on either axle if the vehicle has dual rear wheels or is equipped with wide-base single tires.
 - b. Either bias or radial tires may be used on the steering axle of vehicles with three or more axles.
4. Bias tires and radial tires are mixed in a tandem-drive axle combination on a vehicle equipped with truck tires with 20-inch rim diameter and larger.
5. Any tire on the front wheel of a bus, truck or any tractor truck has a tread groove pattern of less than $4/32$ inch when measured at any point on a major tread groove.
6. Any bus has regrooved, recapped, or retreaded tires on the front wheels.
7. Any motor vehicle, trailer or semitrailer, except the dual wheels installed on motor vehicles having seats for more than seven passengers: (i) operated wholly within a municipality, or (ii) operated by urban and suburban bus lines, which are defined as bus lines operating over regularly scheduled routes and the majority of whose passengers use the buses for traveling a distance of not exceeding 40 miles, measured one way, on the same day between their place of abode and their place of work, shopping areas, or schools, is equipped with a tire that has a tread depth measuring less than $2/32$ of an inch when measured as follows: NOTE: The exemptions provided in clauses (i) and (ii) of this subdivision do not apply to buses owned or operated by any public school district, private school, or contract operator of buses.

NOTE: Measure in two adjacent tread grooves where tread is thinnest. If either of the grooves measure $2/32$ of an inch or more, no further measurements are necessary and tread depth is satisfactory. Do not measure on tread wear indicators.

If both adjacent grooves measure less than $2/32$ of an inch, the tire tread depth must be measured again at two additional equally spaced intervals around the circumference of the tire in a like manner as the first measurement. If the tread depth is less than $2/32$ of an inch in two adjacent tread grooves at each of the equally spaced intervals, the tire must be rejected.

NOTE: Refer to Figures 1, 2, 3, and 4 in this section for illustrations of how to measure tire tread.

MEASURE WHERE THE TREAD IS THINNEST IN TWO ADJACENT TREAD GROOVES

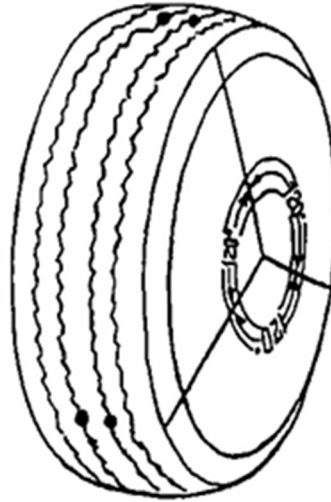

FIGURE 1

IF THE DEPTH IS LESS THAN 2/32-INCH IN BOTH GROOVES MEASURE AT TWO ADDITIONAL EQUALLY SPACED INTERVALS

8. A tire equipped with tread wear indicators if found to have such indicators in contact with the pavement in any two adjacent grooves at three equally spaced intervals around the circumference of the tire. Refer to Figure 2.

REJECT IF THE TREAD WEAR INDICATORS ARE IN CONTACT WITH THE PAVEMENT IN ANY TWO ADJACENT GROOVES AT THREE EQUALLY SPACED LOCATIONS

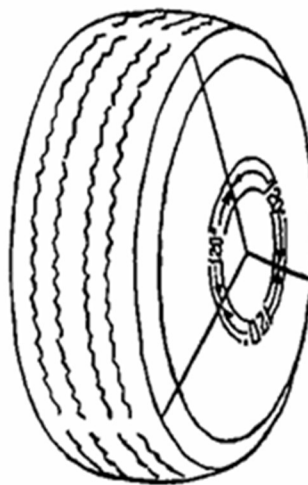

FIGURE 2

9. Any tire has a cut to the extent a ply or belt material is exposed or puncture, not to include a plug or patch that may be used as a manner of repair.

NOTE: Plugs or patches shall be in the tread area only. Plugs or patches are not permitted in the sidewall of the tire.

10. Any tire is worn so that the fabric or steel cord is visible.
11. Any tire has knots or bulges in its sidewalls or if there is evidence of a broken belt under the tread, or if the tread is separating from the fabric.
12. Any tire that has been recut or regrooved except commercial tires so designed and constructed to provide for acceptable and safe recutting and regrooving. Each tire that has been regrooved must be labeled with the word "Regroovable" molded on or into the tire on both sidewalls in raised or recessed letters.
13. Any tire is flat or has an audible air leak.
14. Any tire so mounted or inflated that it comes into contact with its mate or any parts of the vehicle.
15. Rims, or lock rings or wheels are bent, cracked or damaged so as to affect safe operation of the vehicle. Reject if lug nut holes are elongated (out of round).
16. Any wheel studs, bolts, nuts, lugs, or other fasteners (both spoke and disc wheels) are loose, broken, cracked, stripped, missing, or damaged or otherwise ineffective.
17. Any welded repair on aluminum wheels on a steering axle or any welded repair (other than disc to rim attachment) on steel drive wheels mounted on the steering axle.
18. Directional tires or wheels, designed and manufactured to go in a certain direction of rotation not installed in the proper direction of rotation.

FIGURE 3

ATTACHMENT TO BHCS NOTICE DATED 8/21/69

HOW TO MEASURE TIRE TREAD

When measuring tread depth, a gauge calibrated in 32nds of an inch should be used.

The gauge should be placed at the point in one of the treads indicated by an arrow. Depth reading should not be taken in treads marked with a circle, since these are classified as "minor" treads.

Persons taking measurements will have to use discretion in measuring tread depths not pictured here. However, measurements should not be made in treads which are obviously of a "minor" nature.

This guide merely depicts a number of the most common treads.



MAJOR TREAD GROOVE

Grooves in the tread design molded through the complete thickness of the tread rubber running around and/or across the tire surface.

○ MINOR TREAD GROOVE

Remaining tire tread design other than major tread grooves.

⊙ TIE-BAR

Molded rubber located in major tread grooves for the purpose of connecting and supporting the tire treads.

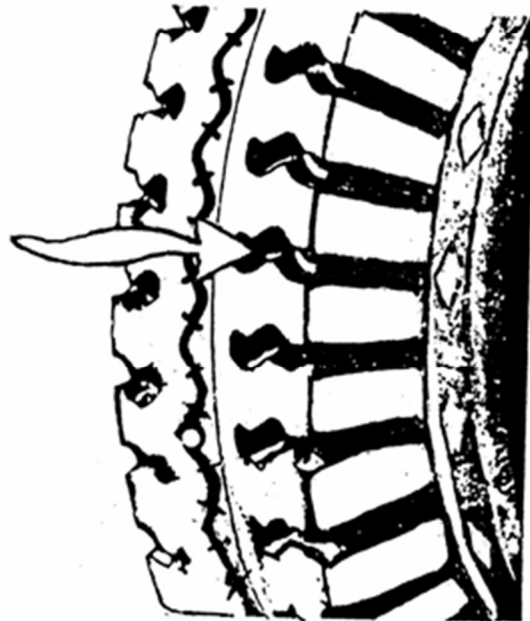
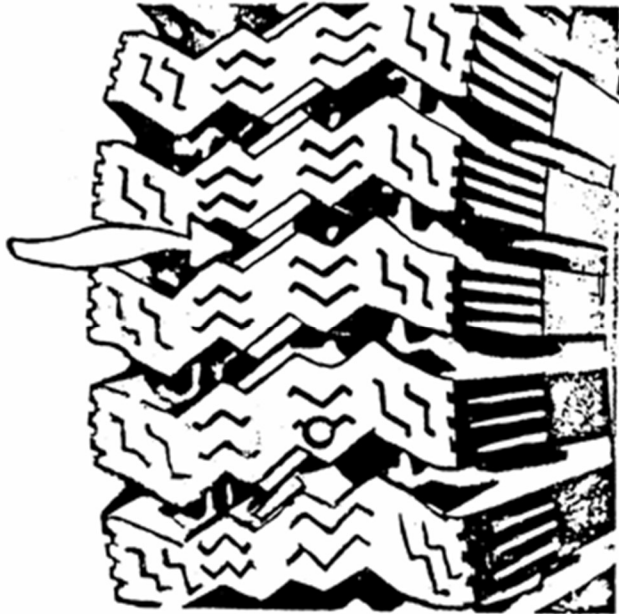
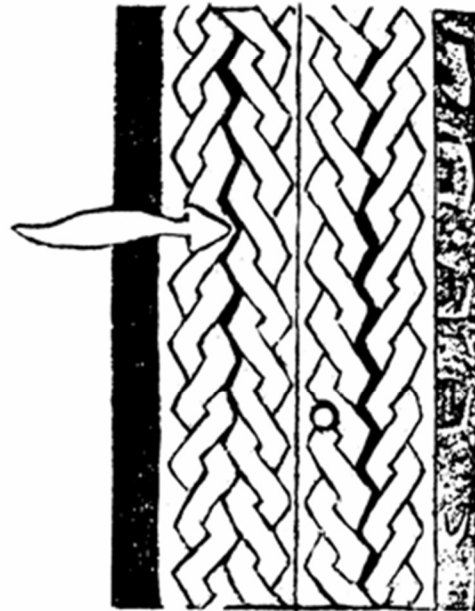

more

FIGURE 4



19VAC30-70-510. Headlamps.

A. Inspect for and reject if:

1. Any motor vehicle is not equipped with at least two headlamps of an approved type. The headlamps must be marked with the headlamp manufacturer's name or trademark, and DOT. If the headlamp bulbs are replaceable, the headlamp lens must be marked with the headlamp light source type (bulb) for which it was designed and the bulb must match the lens code.

NOTE: If the headlamp system is stamped to accept halogen bulbs, then the replacement bulbs must be halogen as well. Retrofitting an HID or LED bulb to a halogen headlamp system does not conform to the standards set forth by the Federal Motor Vehicle Safety Standards (FMVSS) and shall be rejected.

If the entire headlamp assembly is changed from a halogen system to an LED system and does not require the manufacture's original wiring to be cut or compromised, then it shall be considered for inspection if it meets the requirements of subdivision A 2 of this section.

2. Headlights are not of the same approved type (Halogen, HID, LED, etc.) except for sealed beam headlamps, or the replacement headlamp system does not contain all properly marked DOT and SAE stamps certifying that it has met and complied with the standards set forth by the Federal Motor Vehicle Safety Standard (FMVSS) 108.

NOTE: Replacement headlamps stamped with a DOT or SAE approval shall be considered approved by the Superintendent of State Police and will not be required to be listed on the Virginia Motor Vehicle Approved Equipment List.

3. In any headlamp the lens is cracked, broken, discolored, or rotated away from the proper position, or the reflector is not clean and bright.
4. Moisture or water buildup in headlamp is such that it affects the aiming pattern.
5. Headlamps omit light other than white. Light tints of color may be acceptable if the headlamp and headlamp bulbs are marked as required.
6. Bulbs are not of an approved type and marked with all of the following: light source type, the manufacturer's name or trade mark, and DOT.
 - a. Approved headlamp bulbs: HB1, HB2, HB3, HB3A, HB4, HB4A, HB5, H1, H3, H7, H8, H8B, H9, H9B, H9C, H11, H11B, H11C, H13, H13C, H15, HIR1, HIR2, H18, H19.
 - b. Approved headlamp bulbs that require ballast: 9500, D1R, D1S, D2R, D2S, D3R, D3S, D4R, D4S, D5S, D7S, D8S, D9S.
 - c. Approved headlamp ballasts must be marked with the light source type (bulb) and DOT. The bulb type marked on the ballast must match the marking on the headlamp lens.
7. Any filament or bulb in headlamps fails to burn properly or headlamps are not at the same location or configuration as designed by the manufacturer. (Location and type of headlamps can be found in subsection B of this section.)

8. Wiring is dangling or connections are loose, or if proper filaments do not burn at different switch positions, or if switches, including foot or hand dimmer, do not function properly, and are not convenient to the driver.
9. Foreign material is placed on or in front of the headlamp lens or interferes with the beam from the lamp. No glazing may be placed over or in front of the headlamps unless it is a part of an approved headlamp assembly. Reject if the vehicle has wire, unapproved plastic covers, any other materials that are not original equipment or any colored material placed on or in front of the headlamps.

EXCEPTION: A clear impact film known as Headlight Savers produced by Grand Prix Motoring Accessories may be applied to the headlight lens to absorb impact of rocks, etc.

EXCEPTION: A law-enforcement special weapons and tactics (SWAT) or tactical armored vehicle, designed and manufactured exclusively for missions, may apply protective bars in front of the headlamps when designed and installed by the manufacturer.

NOTE: Headlamps, auxiliary driving lamps and front fog lamps shall be mounted so that the beams are aimable and the mounting shall prevent the aim of the lighting device from being disturbed while the vehicle is operating on public roads. All lamps shall be securely mounted on a rigid part of the vehicle.

10. Lamps can be moved easily by hand due to a broken fender or loose support, or if a good ground is not made by the mounting.

Headlamps, auxiliary driving lamps and front fog lamps shall be mounted so that the beams are aimable and the mounting shall prevent the aim of the lighting device from being disturbed while the vehicle is operating on public roads. All lamps shall be securely mounted on a rigid part of the vehicle.

11. A headlamp visor is over two inches long unless part of the original body design.
12. The beam indicator in the driver's compartment does not burn when the high beam is on. (Vehicles not originally equipped with an indicator are not required to comply unless sealed beam headlamps have been installed.)
13. Headlamps are not aimed within the following tolerances using optical aimer:
 - a. The center of the hot spot of all Type 1 lamps, all single element high beam lamps, and all lamps that do not have Type 2 embossed in the lens, is set more than four inches up or down from the horizontal centerline or more than four inches to the left or right from the vertical centerline.
 - b. The left edge of the lamp pattern of any low beam lamp or any combination or multi-element lamp or Type 2 lamp is more than four inches to the left or right of the vertical centerline or the top edge of the lamp pattern is more than four inches above or below the horizontal centerline.

Aiming the Headlamps:

Inspectors shall rely on their education, training, and experience to determine if the headlamps are properly aimed. If improper alignment is observed, headlamps shall be checked for proper aim by using an optical headlamp aimer except on vehicles equipped with on-board aimers.

Headlamp aim on vehicles with on-board aimers shall be checked by visually examining the leveling device mounted either on or adjacent to the headlamp. Reject the vehicle if the leveling device shows the headlamp adjustment to exceed indicated specifications.

NOTE: Driving lamps and fog lamps must be visually inspected to ensure proper aiming. If improper alignment is observed, the optical aimer shall be used to correct any misalignment.

Optical Aimer:

NOTE: Optical aimers must be properly calibrated and used in the manner recommended by the manufacturer.

NOTE: When aiming headlamps, first look for the type of lamp, which will be found embossed on the lens. The type determines which aiming requirements must be followed for the optical aimer.

NOTE: All Type 2 headlamps and all low beam or multi-element headlamps must be set by aiming the lamp pattern with the lamps set on low beam.

NOTE: If attempting to align a composite or sealed beam lamp with a high and low beam within the same housing, align only the low beam. If aligning a four-lamp system with high and low beams in separate housings, it may be necessary to cover the low beam while aligning the high beam, if all four lamps are on at the same time.

NOTE: Pattern should be aimed so that the left edge does not extend to the left or right of straight ahead, and the top of the pattern should be even with the horizontal.

NOTE: All VOL and VOR headlamps will be aimed as follows:

To properly aim a combination multi-element or low beam VOL or VOR headlamp assembly, the headlamp pattern should be aimed on low beam only.

Letters marked on the headlamp cover should properly identify VOL and VOR headlamps.

NOTE: VOL and VOR headlamps will normally have only one adjustment, which will be for the vertical aim only. The horizontal aim should be disregarded, as the horizontal aim is preset at the factory.

Pattern "A" represents the light pattern, as it should appear on the view screen of the approved aimer when checking the low beam pattern on a single element headlamp or a combination multi-element headlamp.

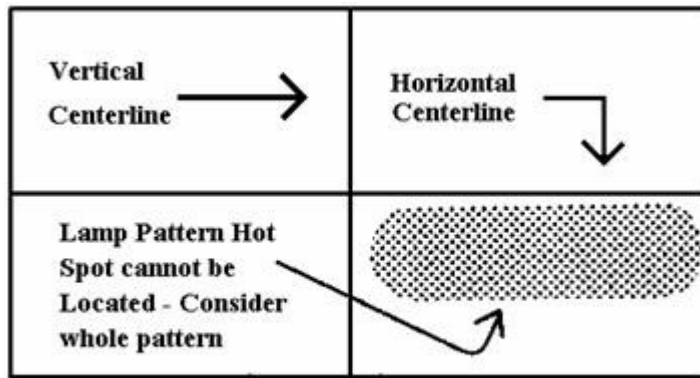

PATTERN A - TYPE 2 LAMP

NOTE: All Type 1 headlamps and all headlamps that do not have Type 2 embossed in the lens shall be set by aiming the center of the hot spot with the lamps set on high beam.

NOTE: Aim straight ahead-center of the hot spot should be centered with the vertical and horizontal centerlines.

Pattern “B” represents the light pattern as it should appear on the view screen of the approved aimer.

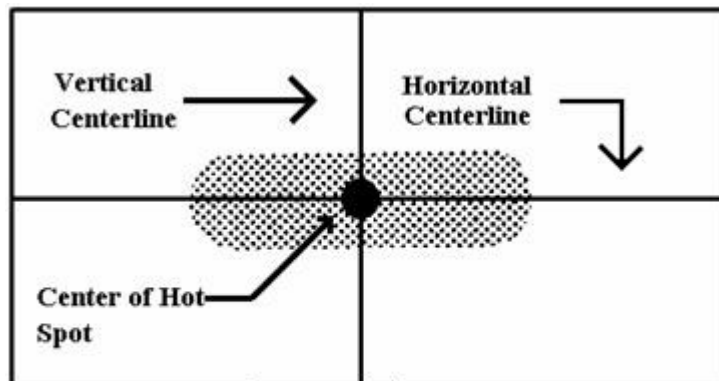

PATTERN B - TYPE 1 LAMP

NOTE: The four headlamp system combines four 5-3/4-inch lamps in pairs.

NOTE: One lamp embossed at the top as Type “1” and one embossed on the top as a Type “2” are arranged as a pair on each side.

NOTE: When lamp pairs are mounted horizontally, the Type “2” lamp must be on the outer side.

NOTE: The four headlamp system must be wired so that only the lower beam in the Type “2” lamps will burn when the light beams are depressed. When switched to high beams, both the Type “1” and Type “2” will burn.

NOTE: Light patterns shown on the following page will be displayed on the most recently approved light machines produced by Hopkins and Symtech Corporations.

Aiming the Headlamps:

NOTE: All headlamps that are found not to be within the four-inch tolerance shall be adjusted to zero inches up or down and zero inches to the right or left.

Headlamps on Vehicles used for Snow Removal:

NOTE: Approved auxiliary headlamps (SAE-Z) may be mounted above the conventional headlamps. (These lamps must be in compliance with 19VAC30-70-140, in its entirety, subdivision 7 of 19VAC30-70-150 and subsection A of 19VAC30-70-170 of this manual.)

B. Inspect for and reject if:

1. Lamps are not an approved type as indicated in subdivision A 6 of this section.
2. Lamps are not mounted in a manner that will permit proper aiming.
3. Lamps are mounted so as to obstruct the driver's vision.
4. The auxiliary headlamp circuit does not contain a switch that will deactivate the primary headlamp system when the auxiliary headlamps are in use.
5. Auxiliary headlamps are not aimed in accordance with the provisions of this section.

HEADLAMP PATTERNS

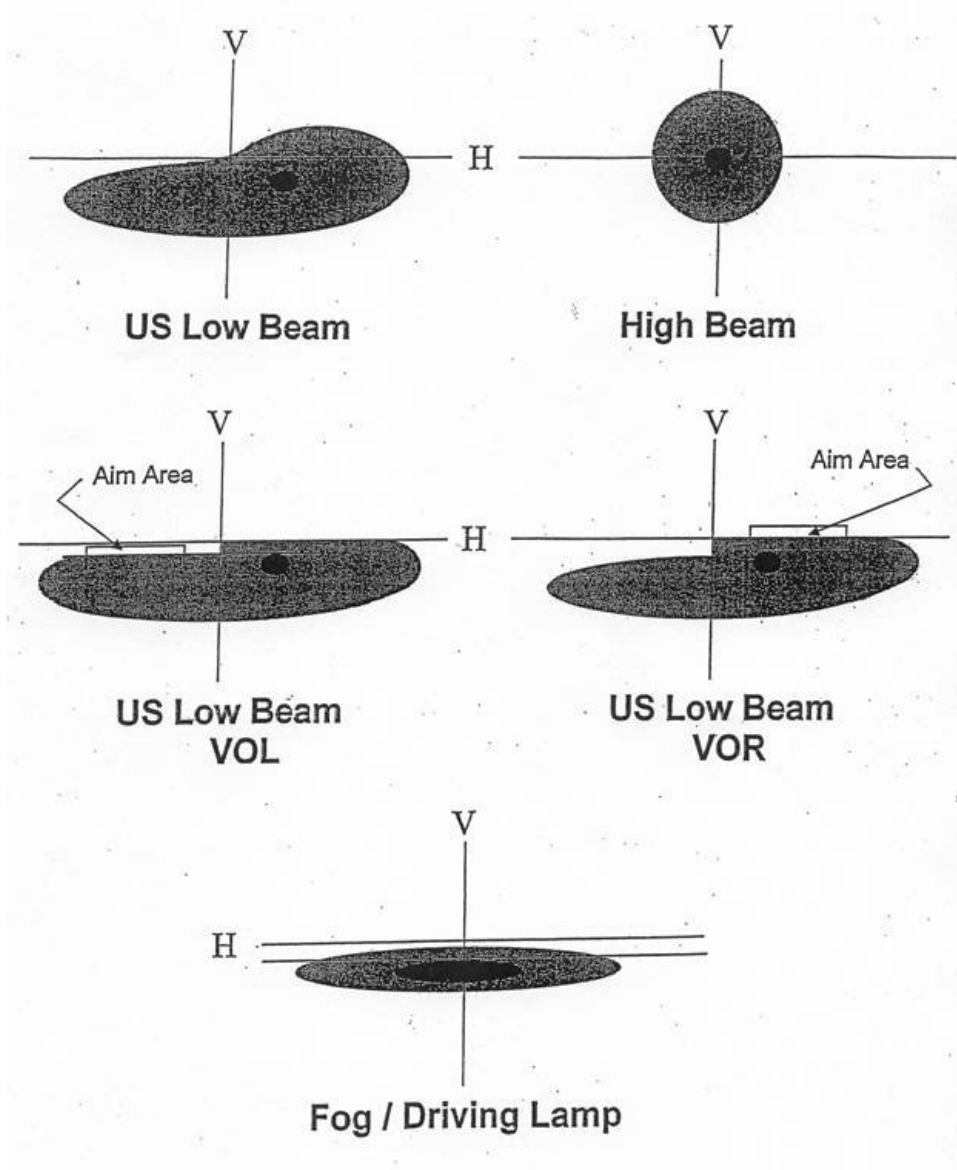

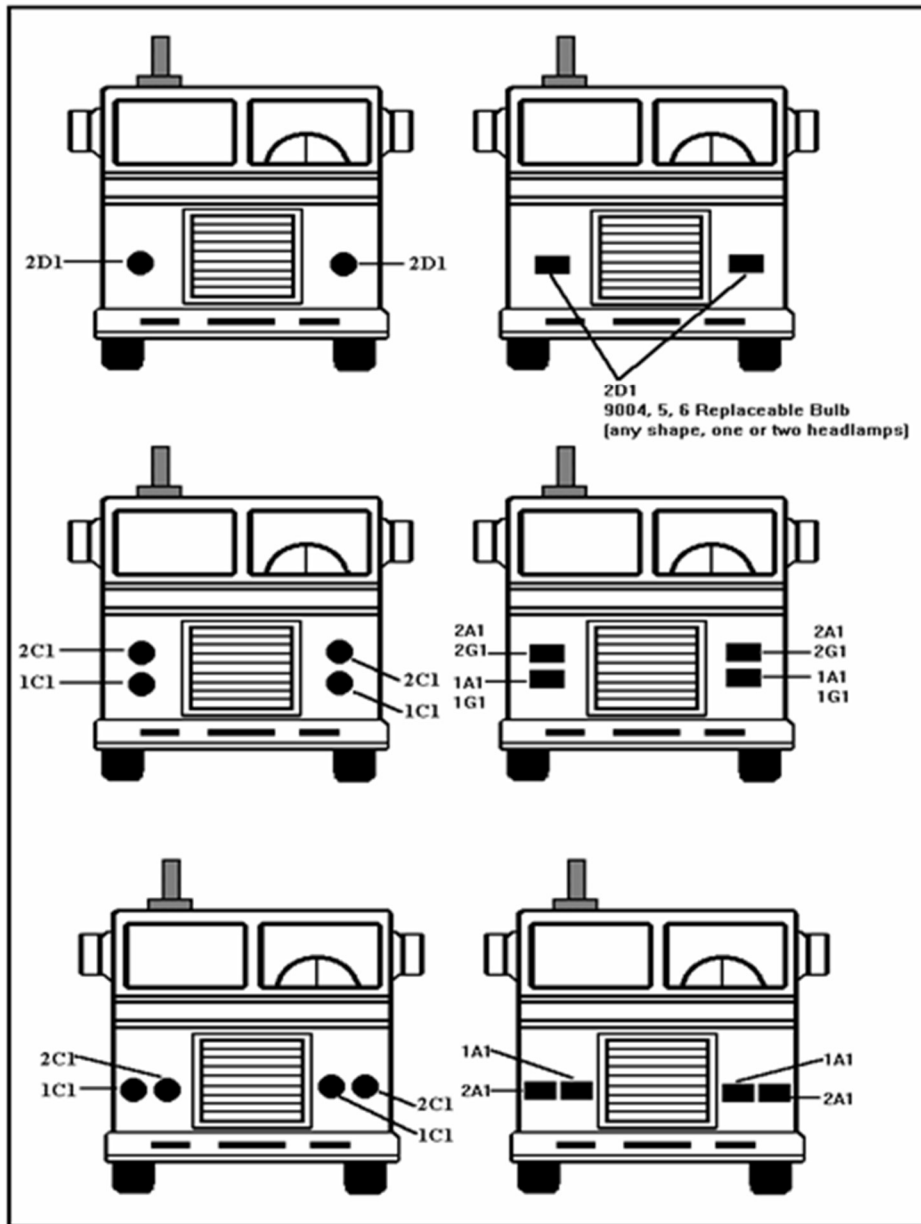

NOTE: ALWAYS inspect the following sealed beam and replacement bulb headlamps on LOW BEAM only:

5-3/4 inch, marked Type 2 or 2CI

b. 7 inch, marked Type 2 or 2DI

- 6-1/2 X 4-1/4 inch rectangular, marked Type 2QA or 2A1

- 2000 X 142mm rectangular, marked Type 2B or 2B1

19VAC30-70-520. Rear lamps: tail lamp; and rear lamp combinations.

A. Inspect for and reject if:

1. Vehicle is not equipped with a rear (tail lamp) or rear lamp combination of an approved type and the light or light assembly does not work as approved.
2. The vehicle is equipped with more than one rear lamp, if all are not in operating condition.
3. The vehicle is not equipped with a license plate lamp that emits a white light. The license plate lamp may be a separate lamp or part of a combination rear lamp. (A road tractor or tractor-truck that does not have a rear license plate is not required to have a license plate lamp.)
4. Lens for license plate lamp is not illuminated by a license plate lamp that emits a white light.
5. Lens on rear lamps, or lens area in combination rear lamps (tail lamps) are not red. LED (light-emitting diode) lights with a clear lens are acceptable. Vehicles equipped with a multiple LED light (not filament-burning bulbs) will pass inspection if more than 50% of the diode lights are burning.
6. Lens has piece broken from it or does not fit properly. The lens may have one or more cracks provided an off-color light does not project through the cracks.

NOTE: Taping or gluing cracks or pieces is not allowed.

7. Filament in all rear (tail) lamps does not burn when headlamp switch is turned on to any position, or if lamps do not provide a red light visible to the rear through an approved red lens as annotated in subdivision 1 of this subsection.
8. Rear (tail) lamp is not mounted near extreme rear of vehicle. Dump trucks and other specially constructed vehicles may mount the rear lamp at a point other than on the extreme rear, provided such rear lamp is clearly visible from the rear, and further provided that a red reflector of an approved type is mounted on the extreme rear. In unusual cases, the rear lamp may be mounted on the cab. Reject if the lamp is hidden by a bolster or other part of the body or frame, is not mounted securely, or if the lamp does not make a good electrical contact.
9. Wiring or electrical connections are defective or filaments do not burn.
10. Any vehicle has unapproved lens or plastic covers, any other materials that are not original equipment or any colored material placed on or in front of rear lamps, tail lamps, or rear lamp combinations.

B. Every trailer shall carry at the rear, two red lights of a type approved by the superintendent.

19VAC30-70-530. Auxiliary lamps: backup; cornering; driving; fog; spot and warning.

- A. For auxiliary lamps on vehicles over 10,000 pounds, refer to section 19VAC30-70-160 as the same regulations apply.

NOTE: Do not reject tractor trucks equipped with cargo lights of an approved type (SAE-G) that are mounted on the rear of the tractor cab and wired through an independent switch used to illuminate brake connectors and fifth-wheels for nighttime hookups.

19VAC30-70-540. Parking lamps.

Parking lamps are not required. However, if installed they must operate and be inspected. Parking lamps may burn in conjunction with the headlamps.

Inspect for and reject if:

1. Lamps are not of an approved type (DOT or SAE-P) or a lamp has been altered.
2. Parking lamps have other than clear or amber lenses showing to the front. If the lens is clear, then the bulb shall be amber.
3. Parking lamps do not burn with the rear lamps.
4. If lens has a piece broken from it. Lens may have one or more cracks provided no off-color light projects through the crack or cracks.
5. Wiring or electrical connections are defective or filaments do not burn.
6. Any vehicle has unapproved lens or plastic covers, any other materials which are not original equipment or any colored material placed on or in front of parking lamps.

NOTE. LED (light-emitting diode) lights with a clear lens are acceptable if of an approved type. For those vehicles that are equipped with a multiple LED light (not filament-burning bulbs), they will pass inspection if more than 50% of the diode lights are burning.

19VAC30-70-550. Clearance lamps, side marker lamps, and reflectors (under 26,000 pounds GVWR).

Inspect for and reject if:

1. Any motor vehicle, trailer, semitrailer or other vehicle is not equipped with clearance lamps if the vehicle is over seven feet wide or if any portion extends four inches or more outside the front fender line.

When a motor vehicle with a trailer attached is presented, the combination may be considered as one unit in meeting this requirement. If presented separately, the individual unit must meet these requirements except that any tractor-truck need not be equipped with rear red dimension or marker lamps.

2. Lamps or reflectors are not of an approved type or a lamp has been altered; any wires are exposed; unapproved lenses or plastic covers; or any other materials that are not original equipment or any colored material placed on or in front of lamps or reflectors.

EXCEPTION: A law-enforcement special weapons and tactics (SWAT) or tactical armored vehicle, designed and manufactured exclusively for SWAT missions, may apply protective bars in front of the clearance lamps, side marker lamps, and reflectors when designed and installed by the manufacturer.

Retro-reflective surfaces. Retro-reflective surfaces other than required reflectors may be used, provided (see diagram):

- a. Designs do not resemble traffic control signs, lights, or devices, except that straight edge striping resembling a barricade pattern may be used.
 - b. Designs do not tend to distort the length or width of the motor vehicle.
 - c. Such surfaces shall be at least three inches from any required lamp or reflector unless of the same color as such lamp or reflector.
 - d. No red color shall be used on the front of any motor vehicle, except for display of markings or placards required by law.
3. Lenses or lamps on the front are not amber and lenses on lamps on the rear are not red or if a lens has a piece broken from it. A lens may have one or more cracks provided an off-color light does not project through the crack or cracks.
 4. Wiring or electrical connections are defective or all filaments do not burn.

NOTE: Vehicles equipped with a multiple LED (light-emitting diode) light (not filament-burning bulbs) will pass inspection if more than 50% of the diode lights are burning.

5. Two amber lamps are not mounted on the front and two red lamps on the rear, so as to indicate the extreme width of the body, and as high on the permanent body as practical, except that approved 180 degree lamps with yellow or amber lens may be mounted on the side of the vehicle at or as near the front as possible, or if the front is not the widest portion, the lamps may be installed on the side and as near that point as possible.

And with the further exception that 180 degree lamps with red lens may be mounted on the side of the vehicle at or as near the rear as possible or if the rear is not the widest portion of the vehicle, the lamps may be installed on the side as near that point as possible.

NOTE: Any vehicle equipped with three red identification lamps with the lamp centers spaced not less than six inches or more than 12 inches apart and installed as close as practicable to the top of the vehicle and as close as practicable to the vertical centerline of the vehicle may have the rear dimension or marker lamps required by subdivision 5 of this section mounted at any height but indicate as nearly as practicable the extreme width of the vehicle.

NOTE: Dump trucks with a high lift body, concrete mixer trucks and other specially constructed vehicles may be equipped with the required clearance lamps not mounted on the extreme rear, provided such red lamps are clearly visible from the rear and provided further that two red reflectors of an approved type are mounted on the extreme rear. In unusual cases the rear lamp may be mounted on the cab and another red reflex reflector placed on the extreme rear.

NOTE: In addition to the required clearance lamps showing to the front and to the rear, a vehicle may be equipped with side marker lamps on the side of the vehicle. When such an installation is used, all of the side marker lamps on the side except the one at or near the rear must have an amber lens. The side marker lamps on the side at or near the rear must have a red lens.

6. Any vehicle covered by subdivision 1 of this section, except school buses, is not equipped with amber reflectors on the sides as near the front as practical, and red reflectors on the rear. The reflectors must be at least 15 inches and not more than 60 inches from the ground. No reflector can have a piece broken from its reflective surface, but may have one or more cracks.
7. Any combination of vehicles whose actual length exceeds 35 feet if the vehicle is not equipped with reflex reflectors of a type approved by the superintendent and mounted on the widest part of the towed vehicle so as to be visible from the front and sides of the vehicle. No reflector can have a piece broken from its reflective surface, but may have one or more cracks.
8. Any passenger vehicle is equipped with clearance lamps, unless such lamps are used to mark the extreme width of the vehicle or used as taxicab identification, or used as supplemental turn signals. (See 19VAC30-70-190 B.)

NOTE: Vehicles so constructed as to make compliance with the requirements of subdivisions 1, 5, 7, and 9 of this section impractical, will be equipped with clearance lamps and reflectors at the most practical location to provide maximum visibility.

9. Any vehicle is not equipped with: two front side marker lights (amber), two rear side marker lights (red), and two rear reflectors (red).

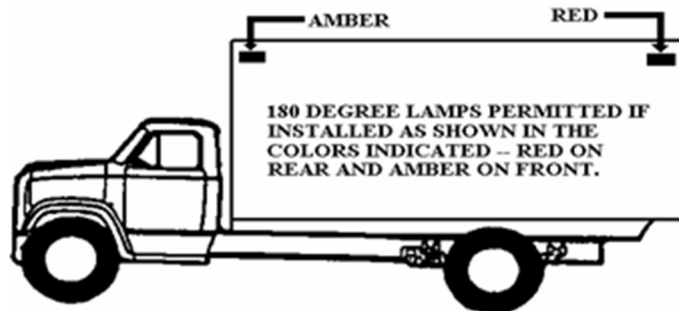
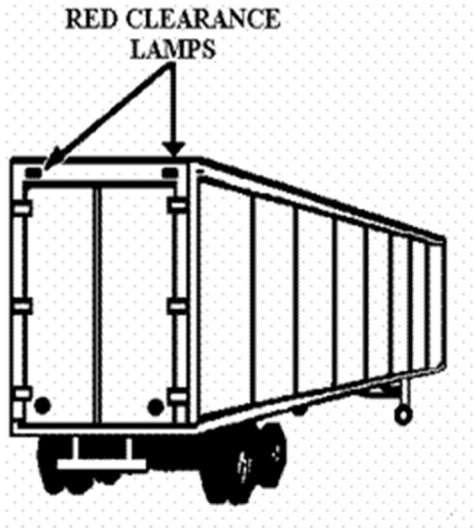
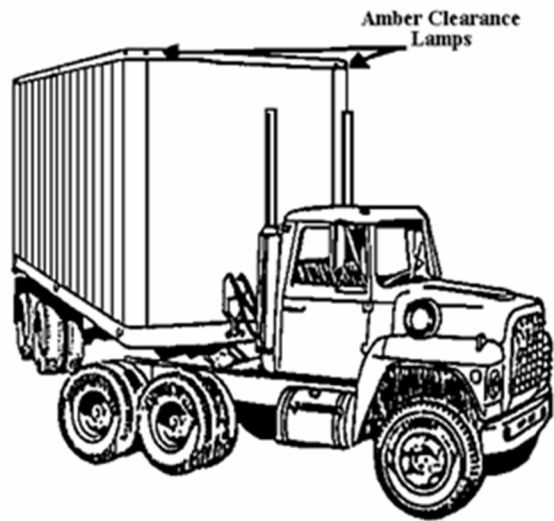

If equipped with three red identification lamps, the required clearance lamps may be mounted at any height so long as they indicate, as nearly as practicable, the extreme width of the vehicle.

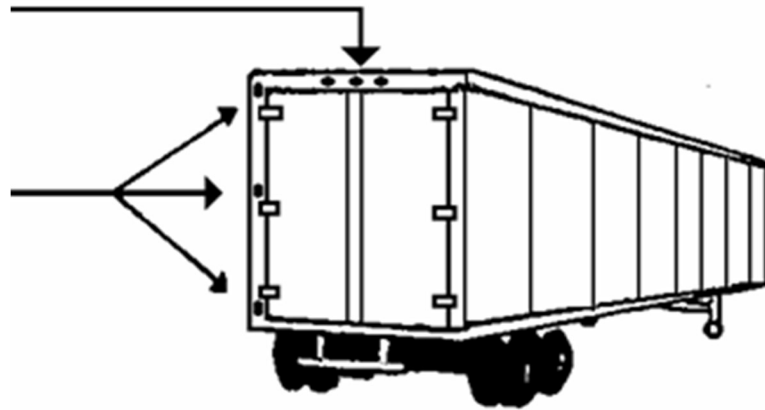

ILLUSTRATIONS FOR PROPER INSTALLATION
OF REFLECTORS

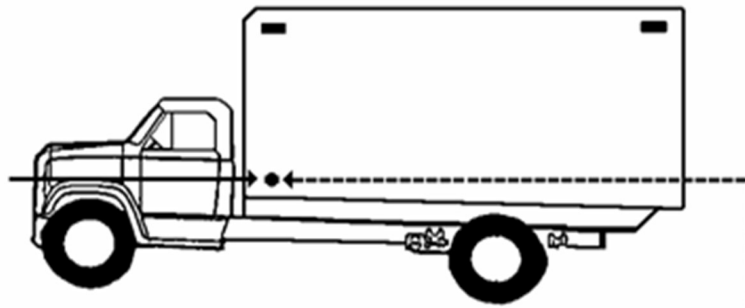

Amber Reflector -- At least 15 inches but not more than 60 inches from the ground

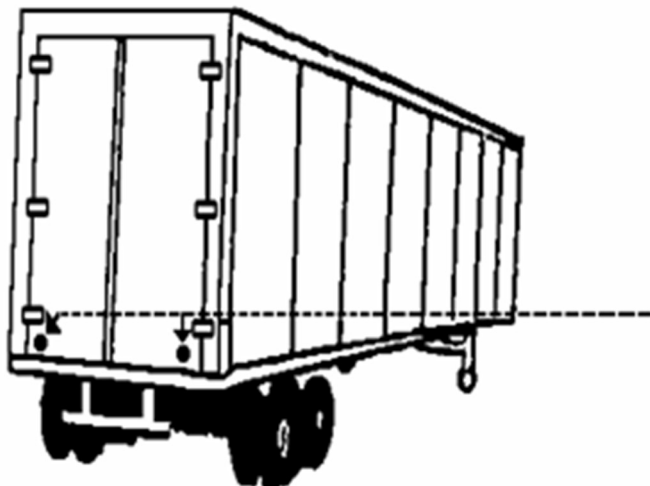

Red Reflectors -- At least 15 inches and not more than 60 inches from the ground

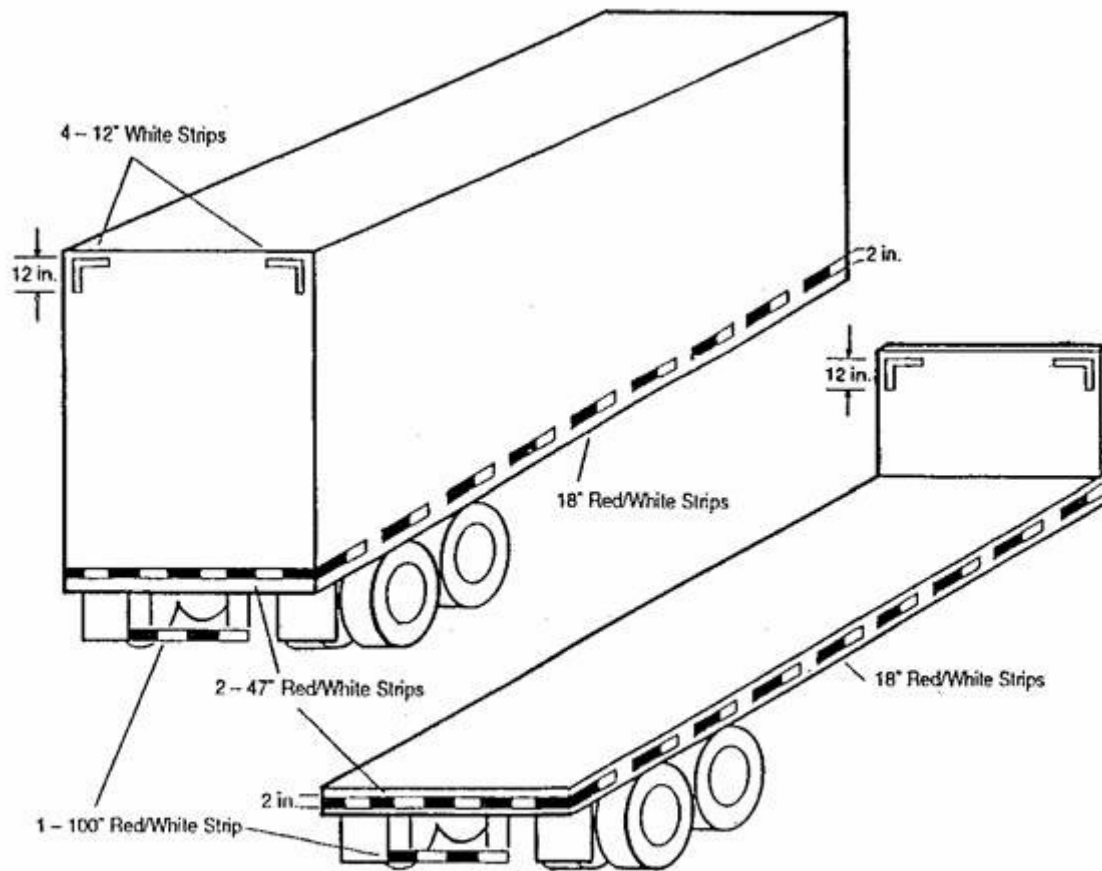

* NOTE: Suggested application meets the requirements for Vehicle Conspicuity as outlined by NHTSA in the December 1992 Final Ruling.

19VAC30-70-560. Signal device (intention to stop or turn), hazard lights, stop lamps.

- A. Any motor vehicle may be equipped with a switch that will permit all turn signal lamps to flash simultaneously.
- B. Supplemental turn signals, properly wired into the turn signal circuit may be installed. These may be either approved type turn signals or clearance lamps.
- C. Inspect for and reject if:
 - 1. Motor vehicle or trailer, except an antique vehicle not originally equipped with a stop lamp, is not equipped with at least two stop lamps of an approved type (DOT or SAES) that automatically exhibit a light through a red or amber lens to the rear when the brake pedal is actuated.
 - 2. Proper signals do not go on with each throw of the switch or if stop signals do not go on with slightest pressure on the brake pedal. Turn signals may flash; however, stop signals may not flash.

Every passenger car manufactured for the 1986 or subsequent model year and multipurpose passenger vehicle, truck, or bus whose overall width is less than 80 inches, manufactured September 1, 1993, and subsequent model year is not equipped with a supplemental center high mount stop lamp of an approved type (DOT or SAEU, U1 or U2) mounted at the vertical centerline of the vehicle that functions only in cooperation with the vehicle's brake lights and hazard lights. Any other vehicle on which a supplemental center high mount stop lamp is mounted shall have the lamp mounted at the vertical center line of the vehicle. The lamps shall be of an approved type and shall function only in conjunction with the stop lamps. The high mount stop lamp must be steady burning and not wired to flash with turn signals or other wigwag device.

“Multipurpose passenger vehicle” means any motor vehicle that is (i) designed to carry no more than 10 persons and (ii) constructed either on a truck chassis or with special features for occasional off-road use.

NOTE: Multipurpose passenger vehicles with an overall width of 80 or more inches or GVWR of 10,000 pounds or more are not required to be equipped with a center high mount stop light.

- 3. Motor vehicle was manufactured after January 1, 1955, and is not equipped with approved signaling devices.
- 4. Vehicle is not equipped with a turn signal if such signal is not working properly or does not continue to function in the same manner as when it was originally manufactured. (The turn signal switch shall lock in place when positioned for a left turn or a right turn, and the turn signal indicators must function. Do not reject a vehicle if the self-canceling mechanism in the switch does not function when the steering wheel is rotated.)
- 5. Switch is not convenient to the driver and/or not of an approved type.
- 6. Any vehicle constructed so as to prevent the operator from making a hand and arm signal, if such vehicle is not equipped with an approved type signaling device.

7. Turn signal lens is not clear or amber to the front, or red or amber to the rear. Lens or bulb color has been altered or modified. If the lens is clear, then the bulb shall be amber.

NOTE: LED (light-emitting diode) lights with a clear lens are acceptable, if of an approved type. For those vehicles that are equipped with a multiple LED light (not filament-burning bulbs), they will pass inspection if more than 50% of the diode lights are burning.

8. Wiring or electrical connections are defective or filaments do not burn.
9. Lens has a piece broken from it. The lens may have one or more cracks provided an off-color light does not project through the crack(s).

NOTE: Taping or gluing cracks or pieces is not allowed.

NOTE: The hazard warning signal operating unit shall operate independently of the ignition or equivalent switch, and when activated, cause all turn signals to flash simultaneously.

NOTE: They are deemed not to be installed if none of the lights burn or flash when the switch is activated and the hazard warning signal flasher unit has been removed.

10. Device is not mounted near rear for rear signals, or near front for front signals (except supplemental turn signals) or if the signal is hidden by a bolster or other part of body chassis.
11. A tractor truck need not be equipped with mechanical or electrical signal devices on the rear if it is equipped with double-faced signal lamps mounted on the front fenders or on the sides near the front of the vehicle clearly visible to the rear.
12. All "Class A" signals are not mounted at least three feet apart. (This does not apply to the combination rear signal device.) However, signal lamps that are mounted as far apart as practical inside and at the rear of the frame so as to be properly visible will meet inspection requirements.
13. Any vehicle has unapproved lens or plastic covers, any other materials that are not original equipment or any colored material placed on or in front of signal device (intention to stop or turn), hazard lights or stop lamp.

ILLUSTRATIONS FOR PROPER INSTALLATION AND TYPE OF SIGNAL LIGHTS

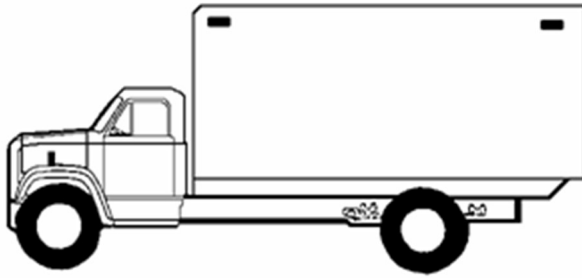

TRUCK: Front
 Permissible --
 Class A Type I
 Class A Type II
 Must show to front --
 may use two faced

TRUCK: Rear
 Permissible --
 Class A Type I
 Class A Type II
 --or--
 Combination
 Arrow Tail Stop
 & Signal



TRACTOR TRAILER: Front
 Permissible --
 Class A Type I
 Class A Type II
 Two faced lamps - must show to
 both front and rear



TRAILER: Rear
 Permissible
 Class A Type I
 Class A Type II

-- or --

Combination
 Arrow Tail
 Stop & Signal

Class A Type I - Are lamps which indicate a change in direction by giving flashing warning signal (clear lens - amber to front; amber to red on rear) on the side toward which the turn will be made.

Class A Type II - Are lamps which indicate a change in direction by means of illuminated arrow heads (flashing or steady) on the side toward which the turn will be made.

Combination



Stop
 Turn
 Tail

Permissible
 on
 rear only

19VAC30-70-570. Permissible lighting equipment.

A. Any vehicle may be equipped with any light in accordance with Title 46.2, Chapter 10, Article 3 of the Virginia Code:

1. Running board or courtesy lamps, of not over six candlepower.
2. Interior lights. (Not more than 15 candlepower.)

Exception: This does not apply to alternating, blinking or flashing colored emergency lights mounted inside law-enforcement vehicles or flashing shielded red or red and white lights, mounted inside vehicles owned or used by members of volunteer fire companies, volunteer rescue squads or owned or used by professional firefighters, or police chaplains. Also, this does not apply to firefighting vehicles equipped with map lights.

3. A motor vehicle having a GVWR of 10,001 pounds or more may be equipped with an illuminated bumper guide attached to each end of the front bumper, provided:
 - a. The light thereon is amber in color and less than six candlepower.
 - b. The light is wired to burn only in conjunction with the marker or clearance lamps on the vehicle.
4. Any approved lamp in good working order when used for the purpose for which it was approved.

B. Inspect for and reject if:

1. Lamps are not of an approved type (DOT or SAE-P2, P3, PC), or do not comply with subsection A of this section.
2. Lamps are not installed on the permanent structure of the vehicle with one as far to the rear and one as far forward as practicable and at a location which is not less than 15 inches above the road surface when measured from the center of the lamp.
3. Lamps installed on the side to the rear do not project a red light and lamps installed on the front do not project an amber light.

NOTE: LED (light-emitting diode) lights with a clear lens are acceptable, if of an approved type. For those vehicles that are equipped with a multiple LED light (not filament-burning bulbs), they will pass inspection if more than 50% of the diode lights are burning.

19VAC30-70-580. Glass and glazing.

- A. Motor vehicles may be inspected without windshields, side glasses, or any kind of glazing except that any motor vehicle other than a motorcycle that was manufactured, assembled, or reconstructed after July 1, 1970, must be equipped with a windshield. If glass or other glazing is installed, it must be inspected. If no windshield is installed, see 19VAC30-70-50 C for location of the sticker.
- B. Inspect for and reject if:
1. Any motor vehicle manufactured or assembled after January 1, 1936, or any bus or school bus manufactured or assembled after January 1, 1935, is not equipped throughout with safety glass, or other safety glazing material. (This requirement includes slide-in campers used on pickups or trucks, caps, or covers used on pickup trucks, motor homes, and vans.)
 2. Any safety glass or glazing used in a motor vehicle is not of an approved type and properly identified (refer to approved equipment section). (Replacement safety glass installed in any part of a vehicle other than the windshield need not bear a trademark or name, provided the glass consists of two or more sheets of glass separated by a glazing material, and provided the glass is cut from a piece of approved safety glass, and provided the edge of the glass can be observed.)
 3. Any glass at any location where glass is used is cracked or broken so that it is likely to cut or injure a person in the vehicle.
 4. Windshield has any cloudiness more than three inches above the bottom, one inch inward from the outer borders, one inch down from the top, or one inch inward from the center strip. The bottom of the windshield shall be defined as the point where the top of the dash contacts the windshield.
 5. Any distortion or obstruction that interferes with a driver's vision; any alteration has been made to a vehicle that obstructs the driver's clear view through the windshield. This may include large objects hanging from the inside mirror or mounted to the windshield, cell phone mounts, GPS devices, CB radios or tachometers mounted on the dash or windshield, hood scoops, and other ornamentation on or in front of the hood that is not transparent.
 - a. Any hood scoop installed on any motor vehicle manufactured for the year 1990 or earlier model year cannot exceed 2-1/4 inches high at its highest point measured from the junction of the dashboard and the windshield.
 - b. Any hood scoop installed on any motor vehicle manufactured for the year 1991 or subsequent model year cannot exceed 1-1/8 inches high at its highest point measured from the junction of the dashboard and the windshield.

NOTE: Antennas, transponders, and similar devices must not be mounted more than 152 mm (six inches) below the upper edge of the windshield. These devices must be located outside the area swept by the windshield wipers, and outside the driver's sight lines to the road and highway signs and signals.

NOTE: Vehicles 10,001 pounds (GVWR) or more, submitted for inspection, with a navigational device, video event recording device, or a crash avoidance camera mounted on the interior of the windshield, when the entire device is mounted not more than four inches

below the upper edge of the area swept by the windshield wipers or not more than seven inches above the lower edge of the area swept by the windshield wipers, shall be issued an approval sticker if no other violations are detected.

6. Windshield glass, on the driver's side, has any scratch more than 1/4 inch in width and six inches long within the area covered by the windshield wiper blade, excluding the three inches above the bottom of the windshield. A windshield wiper that remains parked within the driver's side windshield wiper area shall be rejected.

EXCEPTION: Do not reject safety grooves designed to clean wiper blades if the grooves do not extend upward from the bottom of the windshield more than six inches at the highest point.

7. There is a pit, chip, or star crack larger than 3/4 inch in diameter at any location in the windshield above the topmost portion of the steering wheel except the two-inch border at each side.
8. At any location above the topmost portion of the steering wheel excluding a two-inch border at the top and one-inch border at the sides there is:
 - a. Any crack over 1/4 inch in width.
 - b. Any crack 1/4 inch or less in width intersected by another crack.
 - c. Any damage area 3/4 inch or less in diameter if within three inches of any other damage area.
9. Any sticker is on the windshield other than an official one required by law, or permitted by the superintendent. Authorization is hereby granted for stickers or decals, to include those required by any county, town, or city, measuring not more than 2-1/2 inches in width and four inches in length to be placed in the blind spot behind the rear view mirror. The normal location for any required county, town, or city sticker or decal is adjacent to the right side of official inspection sticker when viewed from inside the vehicle. The top edge of the sticker is to be approximately four inches from the bottom of the windshield. The left side edge adjacent to the official inspection sticker shall not be more than 1/4-inch from the right edge of the official inspection sticker when viewed from inside the vehicle. Valid Commercial Vehicle Safety Alliance (CVSA) inspection decals, or similar commercial vehicle inspection decal issued by local law enforcement, may be placed at the bottom right corner of the windshield when viewed from inside the vehicle. The top edge of such decals are to be approximately four inches from the bottom of the windshield when viewed from inside the vehicle and are to be located outside the area swept by the windshield wipers.

Any sticker or decal required by the laws of any other state or the District of Columbia and displayed upon the windshield of a vehicle submitted for inspection in this state is permitted by the superintendent, provided the vehicle is currently registered in that jurisdiction and the sticker is displayed in a manner designated by the issuing authority and has not expired. This includes vehicles with dual registration, i.e., Virginia and the District of Columbia.

NOTE: Toll transponder devices may be affixed to the inside center of the windshield at the roof line just above the rear view mirror. If space does not allow, then it may be affixed to the immediate right of the mirror at the roof line.

NOTE: A licensed motor vehicle dealer may apply one transponder sticker no larger than one inch by four inches and one barcode sticker no larger than three inches by four inches to the driver's side edge of a vehicle's windshield to be removed upon the sale or lease of the vehicle provided that it does not extend below the AS-1 line. In the absence of an AS-1 line, the sticker cannot extend more than three inches downward from the top of the windshield.

NOTE: Any vehicle displaying an expired sticker or decal on its windshield at the time of inspection, excluding a rejection sticker, shall not be issued an approval sticker unless the owner or operator authorizes its removal. A rejection sticker will be issued versus an involuntary removal.

10. Sunshading material attached to the windshield extends more than three inches downward from the top of the windshield, unless authorized by the Virginia Department of Motor Vehicles and indicated on the vehicle registration.

NOTE: Sunshading material on the windshield displaying words, lettering, numbers or pictures that do not extend below the AS-1 line are permitted.

NOTE: Vehicles with logos made into the glass at the factory that meet federal standards will pass state inspection.

11. Any sunscreening material is scratched, distorted, wrinkled or obscures or distorts clear vision through the glazing.
12. Front side windows have cloudiness above three inches from the bottom of the glass, or other defects that affect the driver's vision or one or more cracks which permit one part of the glass to be moved in relation to another part. Wind silencers, breezes or other ventilator adaptors are not made of clear transparent material.
13. Glass in the left front door cannot be lowered so a hand signal can be given. (This does not apply to vehicle equipped with approved turn signals which were not designed or manufactured for left front glass to be lowered.) If either front door has the glass removed and material inserted in place of the glass which could obstruct the driver's vision.

Exception: Sunscreening material is permissible if the vehicle is equipped with a mirror on each side.

14. Any sticker or other obstruction is on either front side window, rear side windows, or rear windows. (The price label, fuel economy label and the buyer's guide required by federal statute and regulations to be affixed to new or used vehicles by the manufacturer shall normally be affixed to one of the rear side windows.) If a vehicle only has two door windows, the labels may be affixed to one of these windows. If a vehicle does not have any door or side windows, the labels may be temporarily affixed to the right side of the windshield until the vehicle is sold to the first purchaser.

NOTE: A single sticker no larger than 20 square inches in area, if such sticker is totally contained within the lower five inches of the glass in the rear window or a single sticker or decal no larger than 10 square inches located in an area not more than three inches above the bottom and not more than eight inches from the rearmost edge of either front side window, is permissible and should not be rejected.

Do not reject a tractor truck having a gross vehicle weight rating of 26,001 pounds or more equipped with one optically grooved clear plastic wide angle lens affixed to the right front side window. Such wide angle lens shall not extend upward from the bottom of the window opening more than six inches or backward from the front of the window opening more than eight inches.

15. Rear window is clouded or distorted so that the driver does not have a view 200 feet to the rear.

EXCEPTIONS: The following are permissible if the vehicle is equipped with a mirror on each side:

- a. There is attached to one rear window of such motor vehicle one optically grooved clear plastic right angle rear view lens, not exceeding 18 inches in diameter in the case of a circular lens or not exceeding 11 inches by 14 inches in the case of a rectangular lens, which enables the operator of the motor vehicle to view below the line of sight as viewed through the rear window.
- b. There is affixed to the rear side windows, rear window or windows of such motor vehicle any sticker or stickers, regardless of size.
- c. There is affixed to the rear side windows, rear window or windows of such motor vehicle a single layer of sunshading material.
- d. Rear side windows, rear window or windows is clouded or distorted.

19VAC30-70-590. Mirrors.

Inspect for and reject if:

1. Any motor vehicle is not equipped with at least one mirror.
2. Any bus, truck, road tractor or tractor truck is not equipped with two outside rear view mirrors, one at each side, firmly attached.

EXCEPTION: Only one outside mirror shall be required, on the driver's side, on vehicles so constructed that the driver has a view to the rear by means of an inside mirror.

Vehicles equipped with only one outside mirror must have the mirror on the driver's side.

NOTE: No motor vehicle shall be required to be equipped with an inside rear view mirror if it does not have a rear window or if the rear window is so obstructed as to prevent rearward vision by means of an inside rear view mirror, if the motor vehicle has horizontally and vertically adjustable outside rear view mirrors installed on both sides of such motor vehicle in such a manner as to provide the driver of such motor vehicle a clear view along both sides of such motor vehicle for a distance of not less than 200 feet.

3. Reflecting surface of mirror is cracked, broken, peeled, pitted, clouded, tarnished, the image is distorted, has sharp edges, reflects more than one image, or is not mounted securely.
4. Mirror does not give the driver a clear view of the road 200 feet to the rear.
5. Interior rear view mirror;
 - a. Mirror is loose enough that rear view is impaired.
 - b. Mirror cannot be adjusted or will not maintain a set adjustment.
6. Exterior rear view mirror;
 - a. Mirror is loose enough that rear view is impaired.
 - b. Left mirror is obscured by an unwiped portion of windshield or mirror is mounted so it cannot be adjusted from driver's seat. (Applies to 1969 and subsequent model vehicles.)

NOTE: A right side mirror is not required if the reflecting surface of the mirror has been completely removed from the mirror housing. However, a vehicle will be required to have two outside mirrors if there is a sticker or stickers, regardless of size, sun-shading or tinting film, on the rear side windows or rear window.

NOTE: A single sticker, no larger than 20 square inches, if such sticker is totally contained within the lower five inches of the glass of the rear window, and does not obstruct the center high mount brake light, is allowed and will pass inspection.

19VAC30-70-600. Windshield wiper/defroster.

A. Inspect for and reject if:

1. Vehicle is equipped with a windshield and is not equipped with a windshield wiper.
2. Vehicle was manufactured before January 1, 1943, and is not equipped with at least one wiper on the driver's side. This wiper may be operated by hand.
3. Vehicle was manufactured after January 1, 1943, and is not equipped with a windshield wiper or wipers that clear both sides of the windshield; these wipers must be mechanically operated (electrical, vacuum, or air, but not by hand). A switch in good working order must be present to turn the wipers on and off. Any wiper that parks within the area covered by the driver's windshield wiper blade, excluding the three inches above the bottom of the windshield shall be rejected (19VAC30-70-580 B 6).
4. Blade has brittle, worn, torn, or ripped rubber or if metal comes in contact with the windshield; the blade is not securely attached to wiper arm.
5. Wiper does not operate freely; or if it is an electrically or mechanically operated wiper that must be operated by hand.

NOTE: Inspect only wipers found on the front windshield.

B. Windshield Defroster: Vehicles manufactured after January 1, 1969, must be equipped with windshield defroster systems.

Inspect for and reject if:

1. Any 1969 or subsequent model not equipped with a windshield defroster system.
2. Defroster fan fails to function.
3. Fan functions, but a warm stream of air cannot be felt blowing against the windshield. (Engine must be warm and all elements of the defroster system must be in the on position.)

19VAC30-70-610. Horns and other warning devices.

Inspect for and reject if:

1. Vehicle is not equipped with a horn in good working order, capable of emitting a sound audible under normal conditions over a distance of not less than 200 feet and is not firmly mounted.
2. A horn operating mechanism installed at a location readily accessible to the vehicle operator is not provided. Electrically operated horn, wiring, or electrical connections are defective.
3. Vehicles used for garbage and refuse collection and disposal, or vehicles having a manufacturer's gross vehicle weight rating of 10,001 pounds or more and used primarily for highway repair or maintenance are not equipped with a device of an approved type wired through the reverse gear circuit, in good working order, which automatically emits an audible alarm signal when the vehicle is operated in reverse gear.

19VAC30-70-620. Doors.

Inspect for and reject if:

1. If each door located at the left and right side of the driver's seat is not equipped with a handle or opening device similar to that installed by the vehicle manufacturer which will permit the opening of the door from the outside and inside of the vehicle.
2. If each door located to the left and right side of the driver's seat is not equipped with a latching system similar to that installed by the vehicle manufacturer which will hold the door in its proper closed position.

19VAC30-70-630. Hood latch system; Batteries.

- A. "Hood" means any exterior movable body panel forward of the windshield that is used to cover an engine, luggage, storage or battery compartment.
- B. Inspect for and reject if:
 - 1. Each hood is not provided with a hood latch system that will securely hold the hood in its proper fully-closed position.
 - 2. The latch release mechanism or its parts are broken, missing or badly adjusted so that the hood cannot be opened and closed properly.
 - 3. Latching system on a vehicle equipped with a tilt cab is defective, broken, missing, or not properly adjusted so that the tilt cab is held securely when it is in its latched position.
- C. Battery mounting and storage. Inspect for and reject if:
 - 1. A battery is not securely attached to a fixed part of the motor vehicle or trailer. A battery is not protected by a removable cover or enclosure if the battery is installed in a location other than the engine compartment.
 - 2. All brackets, hardware, bolts, and bushings used for securely mounting the battery to the vehicle are not present.
 - 3. Removable covers or enclosures are not substantial and are not securely latched or fastened.
 - 4. The battery compartment does not have openings to provide ample battery ventilation and drainage.
 - 5. Whenever the cable to the starting motor passes through a metal compartment, the cable shall be protected against grounding by an acid and waterproof insulating bushing.
 - 6. Whenever a battery and a fuel tank are both placed under the driver's seat, (i) the battery and fuel tank are not partitioned from each other or (ii) each compartment is not provided with an independent cover, ventilation, and drainage.

19VAC30-70-640. Floor pan.

Inspect for and reject if:

1. The floor pan or inner side panels, front or rear, are rusted out or have any holes other than normal drain holes which allow exhaust gases to enter the occupant compartment or trunk.
2. The floor pan is rusted through or is in such condition to create a hazard to the occupants. (A hole in the floor pan which has been properly repaired by welding, or through the utilization of a metal patch riveted, screwed or welded to its surface is not prohibited. If the floor pan was initially constructed from wood, it may be patched with wood.)

19VAC30-70-650. Seat.

Inspect for and reject if:

1. Any motor vehicle is not equipped with a seat to accommodate the operator.
2. The seat is not securely anchored.
3. Seat adjusting mechanism slips out of set position or seat does not lock in normal upright position. Do not reject the seat if it will not adjust as long as it does not violate subdivision 4 of this section.
4. The seat is not located to permit the operator to have adequate control of the steering and braking mechanisms and other instruments necessary for the safe operation of the motor vehicle.

19VAC30-70-660. Seat belts.

A. Definitions:

“Bus” means a motor vehicle with motive power designed to carry more than 10 persons.

“Designated seating position” means any plain view (looking down from the top) location intended by the manufacturer to provide seating accommodations while the vehicle is in motion, except auxiliary seating accommodations as temporary or folding jump seats.

“Front outboard designated seating positions” means those designated seating positions for the driver and outside front seat passenger (except for trucks which have the passenger seat nearest the passenger side door separated from the door by a passageway used to access the cargo area.)

“GVWR” means gross vehicle weight rating as specified by the manufacturer (loaded weight of a single vehicle.)

“Multipurpose passenger vehicle” means any motor vehicle that is (i) designed to carry no more than 10 persons and (ii) constructed either on a truck chassis or with special features for occasional off-road use. This shall include a minivan.

“Open-body type vehicle” means a vehicle having no occupant compartment top or an occupant compartment top that can be installed or removed by the user at his/her convenience.

“Rear outboard front facing designated seating positions” means those designated seating positions for passengers in outside front facing seats behind the driver and front passenger seat, except any designated seating position adjacent to a walkway, that is located between the seat and the nearside of the vehicle and is designated to allow access to more rearward seating positions.

“Truck” means a motor vehicle with motive power designed primarily for the transportation of property or special purpose equipment.

B. Passive Restraint System:

Inflatable occupant restraint (commonly known as air bags).

Passive belt system (automatic deployment around the occupant after the occupant enters the vehicle and closes the door).

Inspect for and reject if:

1. Not of an approved type.
2. Installation not in compliance as follows:
 - a. All motor vehicle seat belt anchorages and attachment hardware must meet the standards and specifications set forth by the Society of Automotive Engineers, Inc., and Federal Motor Vehicle Safety Standard Number 209, for such anchorages and attachment hardware.
 - b. Any questions concerning the proper installation of seat belt assemblies should be directed to the nearest Safety Division office.

3. Any of the following motor vehicles manufactured on or after July 1, 1971, not having a lap seat belt assembly for each designated seating position:
 - a. Open-body type vehicles;
 - b. Walk-in van type trucks;
 - c. Trucks (GVWR in excess of 10,000 pounds);
 - d. Multipurpose passenger vehicles (GVWR in excess of 10,000 pounds).
4. Any buses manufactured on or after July 1, 1971, not having a lap seat belt assembly for the driver's seating position.
5. All other motor vehicles manufactured on or after January 1, 1976, except those for which requirements are specified in subdivisions 3 and 4 of this subsection, not having lap/shoulder or harness seat belt assemblies installed for each front outboard designated seating position.

Those vehicles originally equipped and sold by the manufacturer with only a lap belt installed for each designated seating position, in compliance with Federal Motor Vehicle Safety Standards, will be deemed to be in compliance with this section.

6. Any seat belt buckle, webbing, or mounting is cut, torn, frayed, or no longer operates properly.
7. Any seat belt anchorage is loose, badly corroded, missing or not fastened to belt.
8. Any truck, multi-purpose vehicle, or bus (except school buses and motor homes) with a GVWR of 10,000 pounds or less, manufactured on or after September 1, 1991, is not equipped with a lap/shoulder seatbelt assembly at all forward facing rear outboard designated seating positions.
9. Any of the heretofore described vehicles manufactured on or after September 1, 1992, are not equipped with lap/shoulder seatbelt assembly located at all forward facing rear outboard designated seating positions on a readily removable seat.

C. Air bag and air bag readiness light. Inspect for and reject if:

1. Air bag. Any defects in the air bag system are noted by the air bag readiness light or otherwise indicated;
2. The air bag has been deployed and has not been replaced (and is not deactivated because of a medical or other exemption and a notice is posted to indicate that it has been deactivated);
3. Any part of the air bag system has been removed from the vehicle; or
4. If the air bag indicator fails to light or stays on continuously.

NOTE: Air bag readiness light. Turn the ignition key to the on position; the air bag readiness light will indicate normal operation by lighting for six to eight seconds, then turning off. A system malfunction is indicated by the flashing or continuous illumination of the readiness light or failure of the light to turn on.

NOTE: Any vehicle not originally manufactured with an air bag readiness light shall not be rejected for not having this item.

19VAC30-70-670. Muffler, exhaust system, and trailer venting.

- A. Flexible tubing may be used anywhere in the exhaust system.
- B. Inspection of exhaust system does not concern noise level.
- C. Inspect for and reject if:
 - 1. There is any leakage of exhaust gases at any point in the system. Do not reject “built-in” drain holes in muffler or tailpipe.
 - 2. A muffler or catalytic converter has been repaired in any manner. The exhaust pipe may be welded to the muffler or catalytic converter. Holes or cracks in the exhaust line have been repaired with a patch or caulking.
 - 3. Tailpipe opening is mashed or pinched.
 - 4. Brackets are loose, broken, or missing.
 - 5. Discharge of exhaust:
 - a. The exhaust system fails to discharge the exhaust to the rear or sides of that part of a property-carrying vehicle which is designed for and normally used for the driver and passengers, and to the rear or sides of the passenger and trunk compartment of passenger vehicles, unless such design is consistent with the original vehicle manufacturer exhaust system.
 - b. The exhaust system of a bus powered by a gasoline engine shall discharge to the atmosphere at or within six inches forward of the rearmost part of the bus.

EXCEPTION: Type I small forward control buses (14,000 GVWR Class) and cutaway model buses (10,000 GVWR or less) may discharge the exhaust behind the rear wheels.

- c. The exhaust system of a bus powered by other than a gasoline engine shall discharge to the atmosphere either:
 - 1) At or within 15 inches forward of the rearmost part of the vehicle; or
 - 2) To the rear of all doors or windows designed to open, except windows designed to be opened solely as emergency exits.
 - 6. Inspection of trailers and semitrailers will include a visual inspection of the venting of cooking or heating appliances to the outside of the trailer or semitrailer to determine if the heating and cooking appliances are adequately vented to the outside to prevent the asphyxiation of occupants of any trailer or semitrailer by the operation of the heating or cooking appliances.
 - a. Reject the trailer or semitrailer if not equipped with a vent or venting system to the outside.
 - b. Reject the trailer or semitrailer if there is any complete or partial obstruction of the vent or venting system.

19VAC30-70-680. Fuel system.

Inspect for and reject if:

1. Any part of the fuel system is not securely fastened.
2. There is fuel leakage at any point in any fuel system.
3. Any fuel tank filler cap is missing.
4. Any fuel tank crossover lines are not protected if they extend more than two inches below the bottom of the tank or sump.
5. Any part of the fuel system comes in contact with the exhaust system.

Part VI
Inspection Requirements for Specialty Vehicles

19VAC30-70-690. Inspection requirements for specialty vehicles.

Inspection procedure - converted electric vehicles.

Inspect for and reject if:

1. Any high voltage cables or conduit containing high voltage cables are not completely covered with orange.

NOTE: No high voltage cables may be grounded to the chassis or frame of the vehicle.

2. A breaker or fuse in the high voltage circuit that contains the traction battery pack and the motor controller is not present.
3. An externally mounted switch to open the high voltage circuit in case of an emergency is not present. Such switch must be located where the fuel tank filler cap was located prior to conversion. Any cover protecting the switch must be able to be opened from the outside of the vehicle.
4. Traction batteries are not mounted in secure nonconductive enclosures that provide for limited access. Multiple enclosures may be used but must be connected by high voltage cables encased in conduit made of metal, composite, or other materials of comparable strength, crush, and abrasion resistant to metal or composite.
5. Conduit made of metal, composite, or other materials of comparable strength, crush, and abrasion resistant to metal or composite, encasing any high voltage cable running under or outside of the vehicle is not secured to the vehicle chassis and does not have proper ground clearance.
6. Labeling on three sides of the vehicle identifying such vehicle as "CONVERTED ELECTRIC" is not present on the vehicle. Each label shall be at least six inches long and consist of lettering at least three inches tall.